

## BUDDYBOX®

Bevel BUDDYBOX® 4 Series

Bevel BUDDYBOX® 5 Series

Helical BUDDYBOX®

Application Product      BUDDYBOX® with Torque Limiter



### 《CAUTION》

- These Products should be handled, installed and maintained by trained technicians.  
Carefully read the maintenance manual before use.
- A copy of this maintenance manual should be sent to the actual user.
- This maintenance manual should be kept by the user for future reference.

# Introduction: Safety Precautions

- Carefully read this maintenance manual and all accompanying documents before use (installation, operation, maintenance, inspection, etc.). Thoroughly understand the machine, information about safety, and all precautions for correct operation. After reading, retain this manual for future reference.
- Pay close attention to the "DANGER" and "CAUTION" warnings regarding safety and proper use.



Improper handling may result in physical damage, serious personal injury and / or death.



Improper handling may result in physical damage and/ or personal injury.

Matters described in  may lead to serious danger depending on the situation. Be sure to observe important matters described herein.



- Transport, installation, plumbing, wiring, operation, maintenance, and inspections should be performed by trained technicians; otherwise, electric shock, injury, fire, or damage to the equipment may result.
- In the case of disassembly, assembly or overhaul of this device, contact the nearest authorized service station.
- When using the equipment in conjunction with **explosion proof motor**, a technician with electrical expertise should supervise the transport, installation, plumbing, wiring, operation, maintenance and inspection of the equipment, so as to avoid a potentially hazardous situation that may result in electrical shock, fire, explosion, personal injury and/or damage to the equipment.
- When the unit is to be used in a system for human transport, a protecting device for human safety should be installed to prevent accidents resulting in personal injury, death, or damage to the equipment due to running out of control or falling.
- When the unit is to be used for an elevator or lifter, install a safety protecting device on the elevator side to prevent falling; otherwise, personal injury, death, or damage to the equipment may result.

# Introduction: Reading the Maintenance Manual, Table of Contents

This maintenance manual is common for “gearmotors”, “reducers” and “the application products BUDDYBOX with Torque Limiter”.

The symbols shown below appear in the upper right or left corner of each page to indicate the classification. Please read the applicable pages.

On **Common** pages, symbols identify distinctions between specific specifications.

Specifications	All specifications are common	Gearmotor		Reducer	Application product
		Without brake	With brake		
Mark					

## Contents

### Common

Introduction: Safety Precautions .....	1
Introduction: Reading the Maintenance Manual, Table of Contents .....	2
1. Inspection Upon Delivery .....	3
2. Storage .....	8
3. Transport .....	8
4. Installation .....	9
5. Coupling with Other Machines .....	10
6. Wiring .....	19
7. Operation .....	22
8. Daily Inspection and Maintenance .....	23
9. Troubleshooting .....	34
10. Construction Drawings .....	36

### Application Product BUDDYBOX with Torque Limiter

11. Wiring .....	42
12. Adjusting Preset Torque .....	44
13. Daily Inspection and Maintenance .....	45
14. Torque Indicator .....	47
15. Construction Drawings .....	48

### Common

16. Warranty .....	51
--------------------	----

## ⚠ CAUTION

- Make sure that the unit is positioned right side up before unpacking. Otherwise, injury may occur.
- Make sure that the unit agrees with your order. Injury or damage to the equipment may occur by using the incorrect product.
- Do not remove the nameplate from the unit.

Make sure of the following when this product arrives.

1. Do the items shown on nameplate agree with the order?
2. Was there no damage during transportation?
3. Are all bolts and nuts tightened firmly?

Consult our agent, distributor, or sales office for any defect or questions.

### 1-1 Inspection of the Nameplate

- Let us know the (1) Nomenclature of gearmotor or reducer, (2) reduction ratio, and (3) serial number when consulting us.

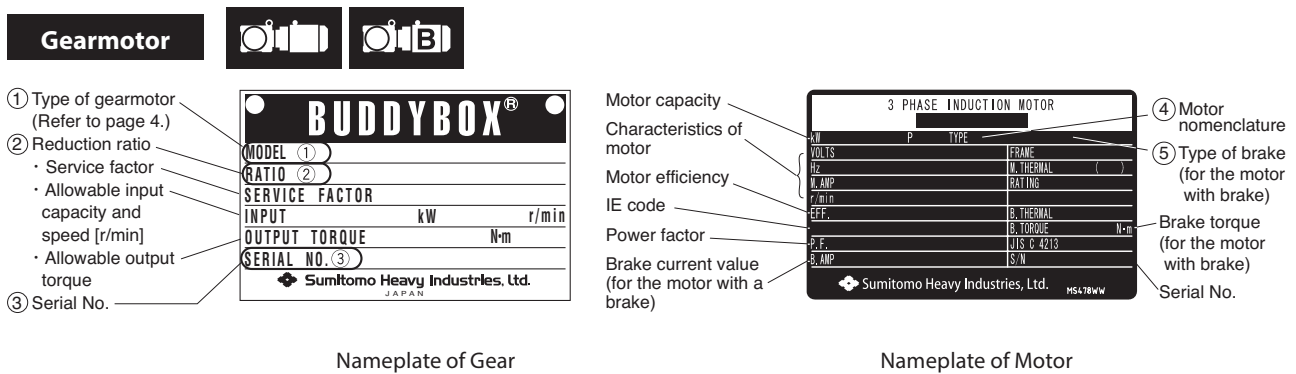

Fig. 1 Nameplate of Gearmotor

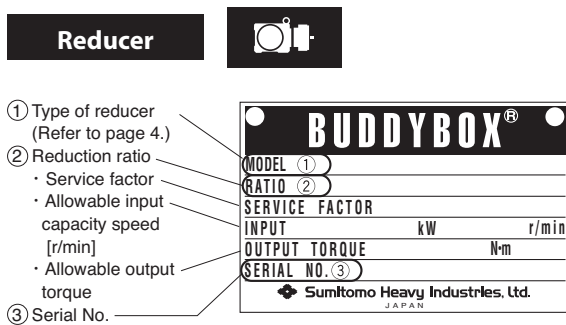

Fig. 2 Nameplate of Reducer

### 1-2 Inspection of Lubrication Method COMMON

Make sure of the lubrication method by referring to section "8-2. Lubrication Method" on page 24.

- **Oil lubrication models** are shipped with out oil. Always supply the unit with recommended oil before operation.
- **Oil supply for two places is necessary for some models for output side and input side, (such as combination of BUDDYBOX and CYCLO).**

## 1-3 Inspection of Nomenclature of Gearmotor or Reducer

Nomenclature shows following information. Make sure it agrees with your order.

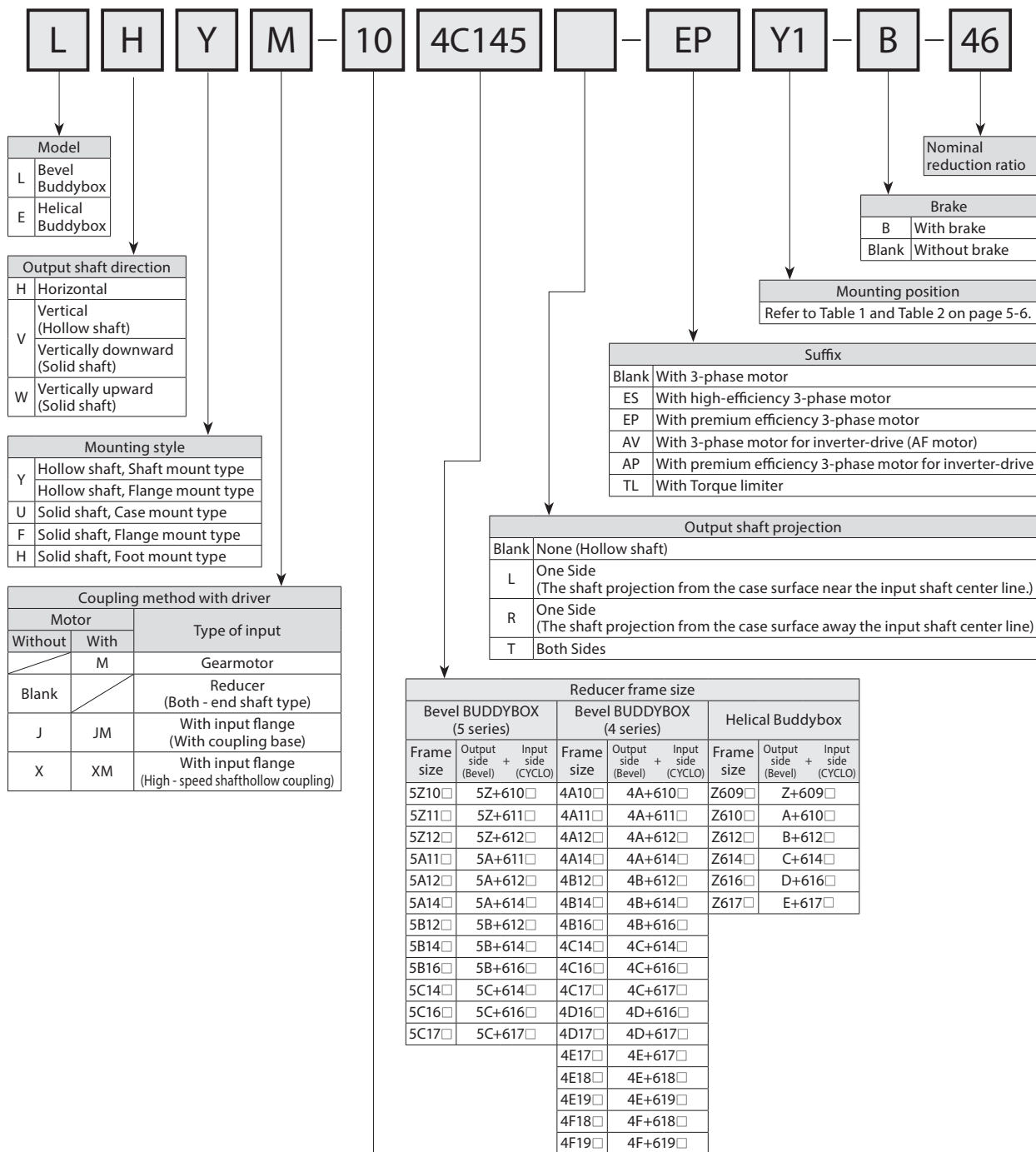

□ indicates 0 or 5, depending on the combination of reduction ratio.

		Motor capacity of gearmotor																				
4-pole	Capacity Symbol	01	02	03	05	08	1	1H	2	3	4	5	8	10	15	20	25	30	40	50	60	75
	kW (HP)	0.1 (1/8)	0.2 (1/4)	0.25 (1/3)	0.4 (1/2)	0.55 (3/4)	0.75 (1)	1.1 (1.5)	1.5 (2)	2.2 (3)	3.0 (4)	3.7 (5)	5.5 (7.5)	7.5 (10)	11 (15)	15 (15)	18.5 (25)	22 (30)	30 (40)	37 (50)	45 (60)	55 (75)

# 1. Inspection upon Delivery Common

Symbol of mounting position / Position of terminal-box / Position of oil filler and drain / Rotation direction of output shaft (Bevel BUDDYBOX)

◇ Oil filler plug    ◆ Oil level (Oli gauge)    ◆ Oil drain plug

**Table 1-a**

<b>"5" Series</b>	LH□M-□-□1	LH□M-□-□2	LH□M-□-□3
	Up	Up	Up
	Down	Down	Down
	Ratio 19-305 Ratio 11-18 364-4365	Ratio 19-305 Ratio 11-18 364-4365	Ratio 19-305 Ratio 11-18 364-4365
LH□M-□-□4	LV□M-□-□5	LV□M-□-□6	
Up	Up	Up	
Down	Down	Down	
Ratio 19-305 Ratio 364-4365	Ratio 19-305 Ratio 11-18 364-4365	Ratio 19-305 Ratio 11-18 364-4365	

**Table 1-b**

<b>"4" Series</b>	LH□M-□-□1	LH□M-□-□2	LH□M-□-□3
	Up	Up	Up
	Down	Down	Down
	Ratio 19-305 Ratio 11-18 364-10658	Ratio 19-305 Ratio 11-18 364-10658	Ratio 19-305 Ratio 11-18 364-10658
LH□M-□-□4	LV□M-□-□5	LV□M-□-□6	
Up	Up	Up	
Down	Down	Down	
Ratio 19-305 Ratio 364-10658	Ratio 19-305 Ratio 11-18 364-10658	Ratio 19-305 Ratio 11-18 364-10658	

# 1. Inspection upon Delivery

**Symbol of mounting position / Position of terminal-box / Position of oil filler and drain / Rotation direction of output shaft (Helical BUDDYBOX)**

◇ Oil filler plug    ◆ Oil level (Oli gauge)    ◆ Oil drain plug

**Table 2**

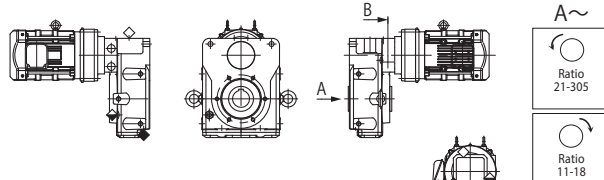
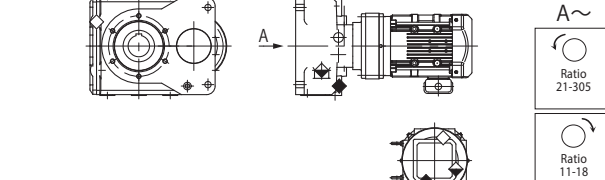
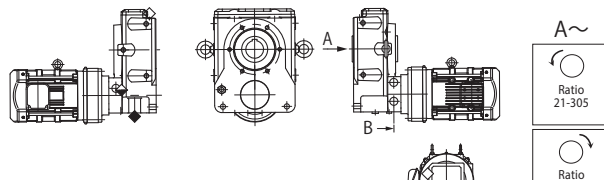
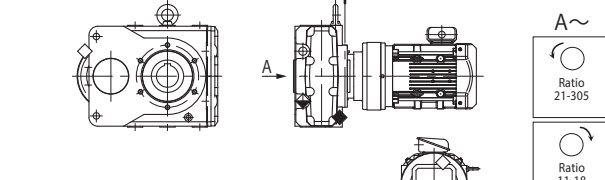
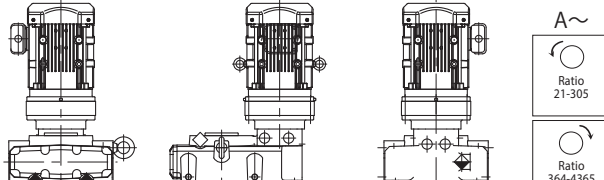
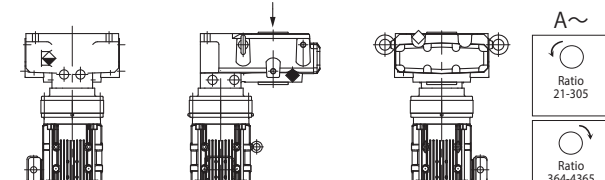
<p style="text-align: center;">EH□M-□-□1</p> <p style="text-align: center;">Up</p>  <p style="text-align: center;">Down</p>	<p style="text-align: center;">EH□M-□-□2</p> <p style="text-align: center;">Up</p>  <p style="text-align: center;">Down</p>
<p style="text-align: center;">EH□M-□-□3</p> <p style="text-align: center;">Up</p>  <p style="text-align: center;">Down</p>	<p style="text-align: center;">EH□M-□-□4</p> <p style="text-align: center;">Up</p>  <p style="text-align: center;">Down</p>
<p style="text-align: center;">EV□M-□-□5</p> <p style="text-align: center;">Up</p>  <p style="text-align: center;">Down</p>	<p style="text-align: center;">EV□M-□-□6</p> <p style="text-align: center;">Up</p>  <p style="text-align: center;">Down</p>

# 1. Inspection upon Delivery



## 1-4 Motor Nomenclature

Nomenclature shows following information. Make sure it agrees with your order.

• Refer to related manual for units with servo motor or DC motor.

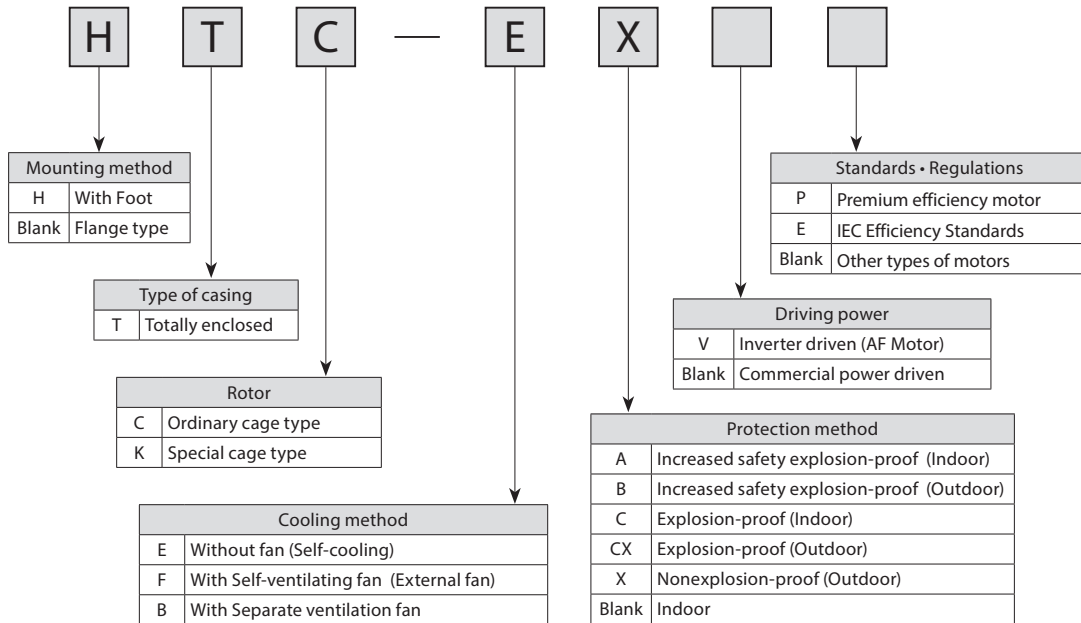



Note the following on storing gearmotor or reducer, when not using the unit right away.

### 2-1 Storage location

Store the unit indoors in a clean dry place.

- Avoid storage outdoors or in places with humidity, dust, sudden temperature changes or corrosive gas.

### 2-2 Storage period

1. Do not store the unit for more than 6 months.
2. Consult us when storing the unit for more than 6 months. Special rustproof specification is necessary.
3. Consult us when exporting the unit. Special rustproof specification is necessary.

### 2-3 Use after storage

1. Make sure that there are no deteriorations in non-metal parts, such as oil seal and oil supply plug, before operating after extended period of storage. Non-metal parts may deteriorate easily by the effect of ambient condition, such as temperature and ultraviolet rays. Replace the deteriorated parts with new parts.
2. Make sure that there is no abnormal noise, vibration, or temperature rise when starting. Make sure that the brake functions normally when for types with brake. Consult our distributor or sales office immediately if any abnormality is found.

### DANGER

- Do not stand below the unit when it is lifted. Injury or death may result.

### CAUTION

- Be careful not to let the unit drop or fall when moving the unit. Always use the metal hanging piece for gear or motor with it. But do not hang the unit using the metal hanging piece after mounting with application machine. Otherwise, it may cause personal injury or damage to the equipment and/or damage to the equipment.
- Make sure of the mass of gearmotor or reducer by looking at the nameplate, packaging, drawing, catalog, etc., before lifting. Do not lift the gearmotor or reducer, which are heavier than the rated weight of the lifting equipment. Otherwise, it may cause injury or damage to the equipment and lifting device.

## **DANGER**

- Use explosion-protection type motor in explosive environment. Do not use the standard unit in explosive environment. Otherwise, it may cause explosion, ignition, electric shock, injury, fire, or damage to the equipment.
- Use the sufficient motor for **explosion-protection motor** matching the hazardous location (where explosive gas or steam exists).
- Inverter itself is not explosion-protection type for **flameproof type motor**. Always set the unit where there is no explosive gas. Otherwise, explosion, ignition, electric shock, injury, fire, or damage of the equipment may occur.

## **CAUTION**

- Do not use gearmotor or reducer for specifications other than the one shown on the nameplate or manufacturing specification document. Otherwise, injury or damage of the equipment may occur.
- Do not place any combustible object around the gearmotor. Otherwise, fire may occur.
- Do not place any object that may prevent ventilation around the gearmotor or reducer. Otherwise, it may lead to burn or fire by abnormal temperature caused by the decreased cooling effect.
- Do not step on or hang from the gearmotor and reducer. Otherwise, it may cause injury.
- Do not touch the shaft end, internal keyway, or edge of motor cooling fin with bare hands. Otherwise, it may cause injury.
- Install an oil pan or other device to prevent damage for extremely oil-sensitive applications, such as food production machine. Otherwise, it may cause defective products by oil leakage when failure occurs or at the end of lifetime.

### 4-1 Place of installation

Ambient temperature: -10~40°C

Ambient humidity: 85% or less

Altitude: 1,000m or lower

Atmosphere: There should be no corrosive or explosive gas or steam.

The location should be free of dust and well-ventilated.

Location: Indoor (location free of dust without water splash)

- Consult us when operating under conditions other than the above. Special specification is necessary.
- Units made according to certain specification, such as for outdoor or for explosion protection, may be used under specified mounting environment.
- Install the unit in location where various procedures can be carried out easily, such as inspection and maintenance.
- Install the unit to a sufficiently rigid base.

### 4-2 Angle of installation

Install the unit horizontally. Consult us for sloped installation.

Do not use the unit made for given slope for other slopes.

Standard shaft direction for **outdoor type gearmotor** is horizontal. Consult us for other shaft directions.

- Do not remove the eye-bolt on the motor. When the eye-bolt is removed for any reason, place a bolt in the tapped hole temporarily. Waterproof treatment is necessary to prevent water entering the motor.

### 4-3 Under Severe Load Condition

For operation with severe vibration and frequent startup, it is recommended to tighten bolt with at least class 8.8 (by standard JIS B-1051).

**⚠ CAUTION**

- Make sure of the rotation direction of the application machine before coupling. Difference in rotation direction may cause injury or damage to the equipment.
- Remove the temporary key on the output shaft when operating the gearmotor or reducer unit alone. Otherwise, it may cause injury.
- Place a cover to prevent touching the rotating parts. Otherwise, it may cause injury.
- Be careful of the center alignment, belt tension, and parallelism of the pulleys when coupling the gearmotor or reducer to the load. Make sure of the coupling accuracy for applications with direct connections. Adjust the belt tension correctly for applications with belt. Make sure to tighten the bolt for pulley, and coupling before operation. Failure to do so may result in damage of equipment or injury by broken pieces.

## 5-1 Confirmation of direction of rotation

**Gearmotor**



Fig. 3 and 4 indicates rotational direction of output shaft when wired following Fig. 25 on page 21.

- Motor shaft turns in clockwise looking from the anti-load side. This direction is as shown by the arrow in Fig. 3 and 4.
- Exchange connection R and T in Fig. 25 on page 21 with each other when rotating in the opposite direction.

**Reducer**



Relationship of rotational direction of input shaft and output shaft is as shown by the arrow in Fig. 3 and 4.

Fig. 3 Rotational Direction of Output Shaft for Bevel BUDDYBOX

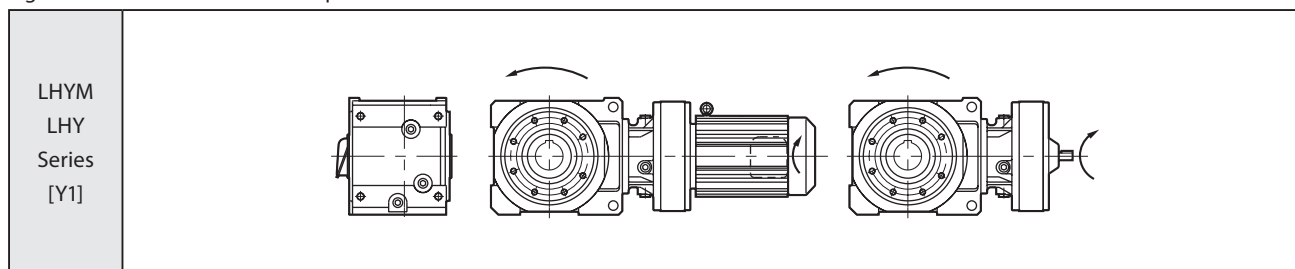

Note: • Models with reduction ratio 11 - 18 and reducers with "DA," "DB," and "DC," at the end are different from the above. Rotational direction of output shaft is opposite from the above figure when the motor shaft and reducer type input is clockwise  
 • Figure above is the rotational direction for mounting style "Y1." Refer to Table 1 on page 5 or catalog for other mounting styles.

Fig. 4 Rotational Direction of Output Shaft for Helical BUDDYBOX

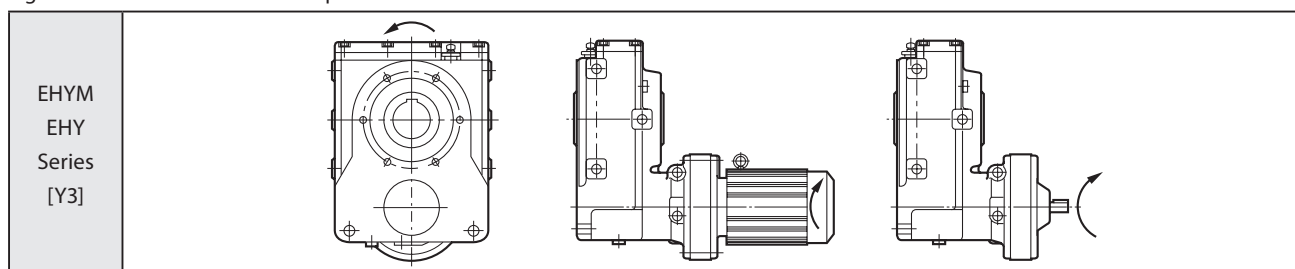

Note: • Models with reduction ratio 11 - 18 and reducers with "DA," "DB," and "DC," at the end are different from the above. Rotational direction of output shaft is opposite from the above figure when the motor shaft and reducer type input is clockwise  
 • Figure above is the rotational direction for mounting style "Y1." Refer to Table 2 on page 6 or catalog for other mounting styles.

## 5-2 Installation of coupling

- Do not apply shock or excess axial load to the shaft when attaching the coupling. It may cause bearing damage or collar may fall off.
- We recommend attachment by shrink fitting.

### (1) When Using Coupling

Adjust the dimensions in Fig. 5 (A, B, and X) within the tolerance shown in Table 3.

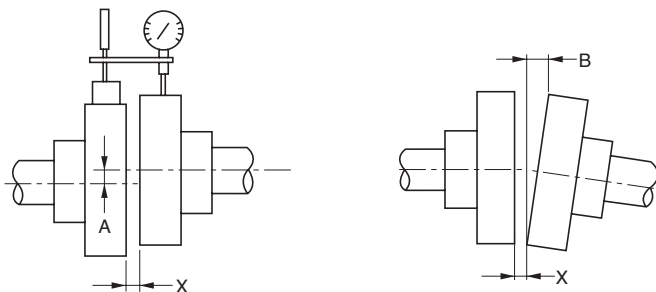

Fig. 5

Table 3 Centering Accuracy of Flexible Coupling

Tolerance for A dimension	0.1mm or maker's specification
Tolerance for B dimension	0.1mm or maker's specification
X dimension	Maker's specification

### (2) When Using with Chain Sprocket and Gear

- Make the tension angle of the chain perpendicular to the shaft.
- Refer to your catalog and other materials on chain for correct tension.
- Use sprocket and gears with pitch diameter at least three times of shaft diameter.
- Make the load point of sprocket and gear closer than the shaft center to the gearmotor or reducer side (Refer to Fig. 6).

### (3) When Using with V-belt

- Too much tension on v-belt will damage the shaft and bearing. Refer to your catalog and other materials on v-belt for correct tension.
- Make the parallelism and eccentricity (b) between two pulleys 20' or smaller (Refer to Fig. 7.)
- Use the matched set with same circumferential length when using multiple v-belts.

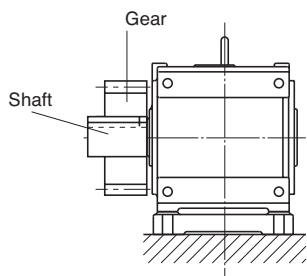

Fig. 6

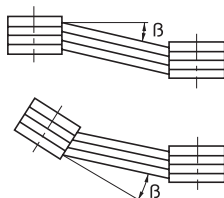

Fig. 7

## 5-3 Coupling **hollow shaft type** with other machines

### (1) Attachment and Removal of Hollow shaft and Driven Shaft

#### (a) Attachment to Driven Shaft

Apply molybdenum disulfide grease to the surface of driven shaft and inner diameter of hollow shaft. Insert the gearmotor or reducer to driven shaft.

Pound the end surface of hollow shaft lightly with a wooden hammer when the fitting is tight.

Do not pound casing and oil seal for this purpose. Jigs as shown in Fig. 8 can help smooth insertion when the fitting is especially tight.

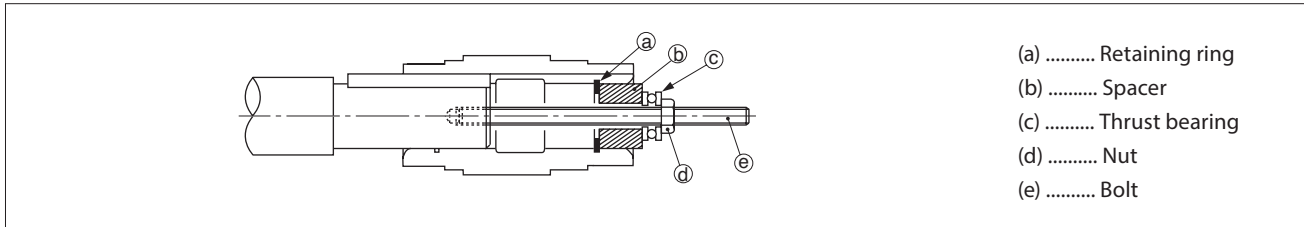

Fig.8 Coupling jig

Hollow shaft conforms to JIS H8.

Make the fitting between hollow shaft and driven shaft when there is shock load or when the radial load is large. (js6 or k6 of JIS standard is recommended for driven shaft.)

#### (b) Uncoupling from driven shaft

Make sure there is no excess force between casing and hollow shaft. Jig as shown in Fig. 9 can help smooth removal.

Prepare jig and parts for attachment, fixing, and removal by yourself.

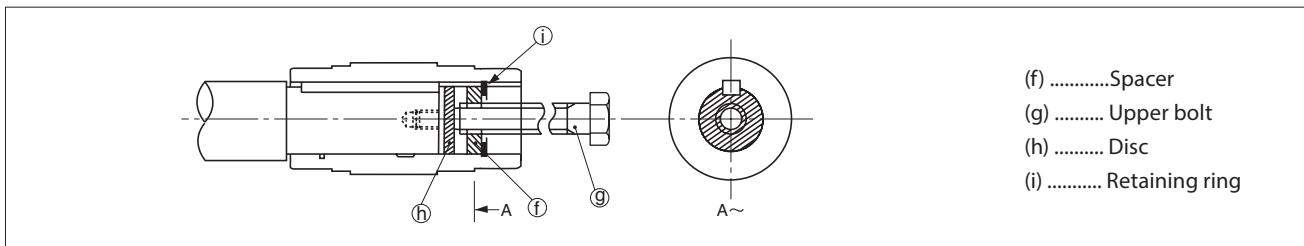

Fig.9 Uncoupling jig

## (2) How to attach of torque arm (option)

### ● Attention of attachment

- 1 Attach torque arm to the application machine side of the reducer.
- 2 Attach retainer parts of torque arm (refer Fig.11) to release extra force between the reducer and the driven shaft.  
(Retainer is to be supplied by customer.)
- 3 Never lock the torque arm completely with locking bolts and such.
- 4 Attach shock-absorbing material between torque arm and attachment bolt (or spacer).
- 5 Use bolt which meets JIS standard of screw strength ranking by 10.9 or above.
- 6 Bolts must be made to lock when a torque arm is used. (The method to lock is to use U-nut or spring washer, or to supply adhesive for locking screw, etc.)

Note: As shock-absorbing material, rubber bushes and spring washers are prepared.

By use and operating condition, different shock-absorbing materials are recommended.

- In the case of one direction operation : Spring washers or rubber bushes
- In the case of start-stop operation : Spring washers



Attachment type torque arm (option)



Banjo type torque arm (option)

Fig.10 Example of using torque arm

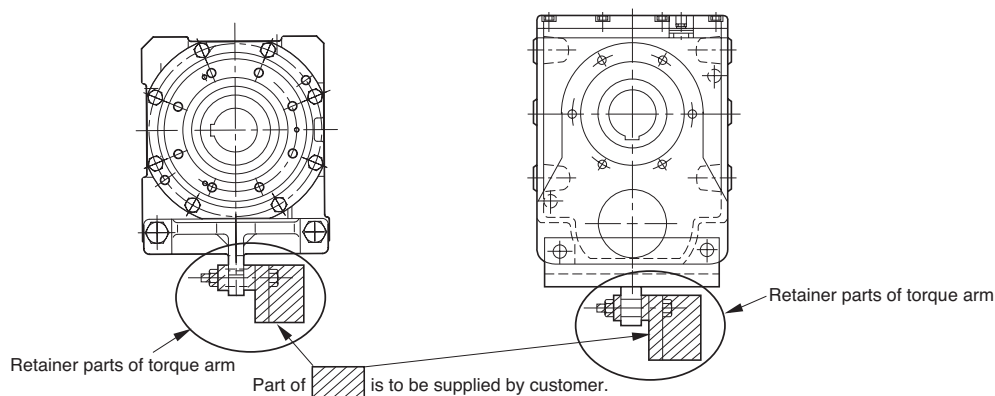

Fig.11 Example of retainer (for attachment type torque arm)

### (3) Attachment of shock absorbing material (option)

#### ● How to attach with spring washers

- The spring washers that our supply are equivalent to DIN 2093 standardized.
- Use the bolts that have more than 10.9 for JIS strength class.
- Attach the spring washers without gap in the part of attachment ("A" in fig.13 ).  
If there is gap in the part of attachment, it is afraid that the torque arm is damaged.
- Check spring washers that are smashed. If the spring washers are attached with tightening of nuts such that they are smashed, they are afraid that spring washers have no function for shock absorbing ,and that BUDDYBOX and the machine of the customer are suffered too much force. In the case of using double nuts, be careful to tighten them without smashing of spring washers.
- For the wear reduction of the spring washers, apply any lubricant such as grease to faces of contacting each spring washers.
- Make always the bolts looseness prevention such as using adhesive for looseness or U-nuts.
- In the case that gap is arise on the part of attachment by initial sag of spring washers, adjust to turn gap to zero-gap with secondary tightening of the nuts.

Then be careful not to smash the spring washers.

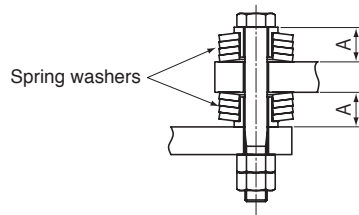
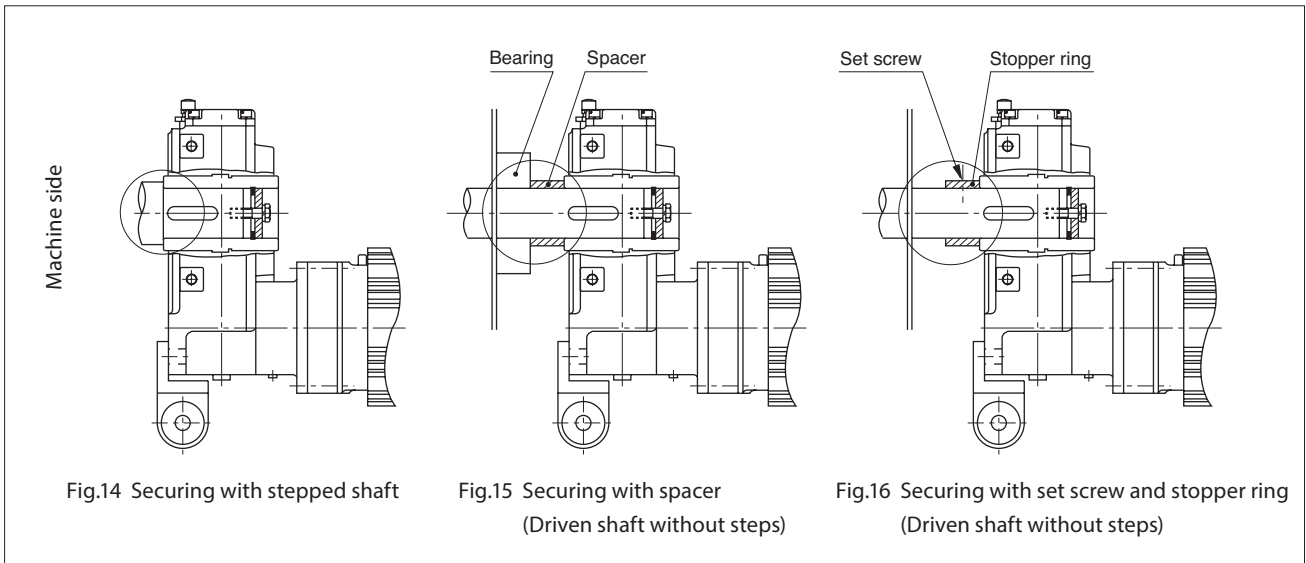

Fig.13 Example of spring washers attachment

Fixing to Driven Shaft: Always engage the gearmotor with driven shaft when stopping the whirl by attachment method or tie-rod method.

Fixing Example to Prevent Gearmotor Moving to the Machine side  
(Overhead view of EHYM3-A6105)



Fixing Example to Prevent Gearmotor Moving to the Machine side  
(Overhead view of EHYM3-A6105)

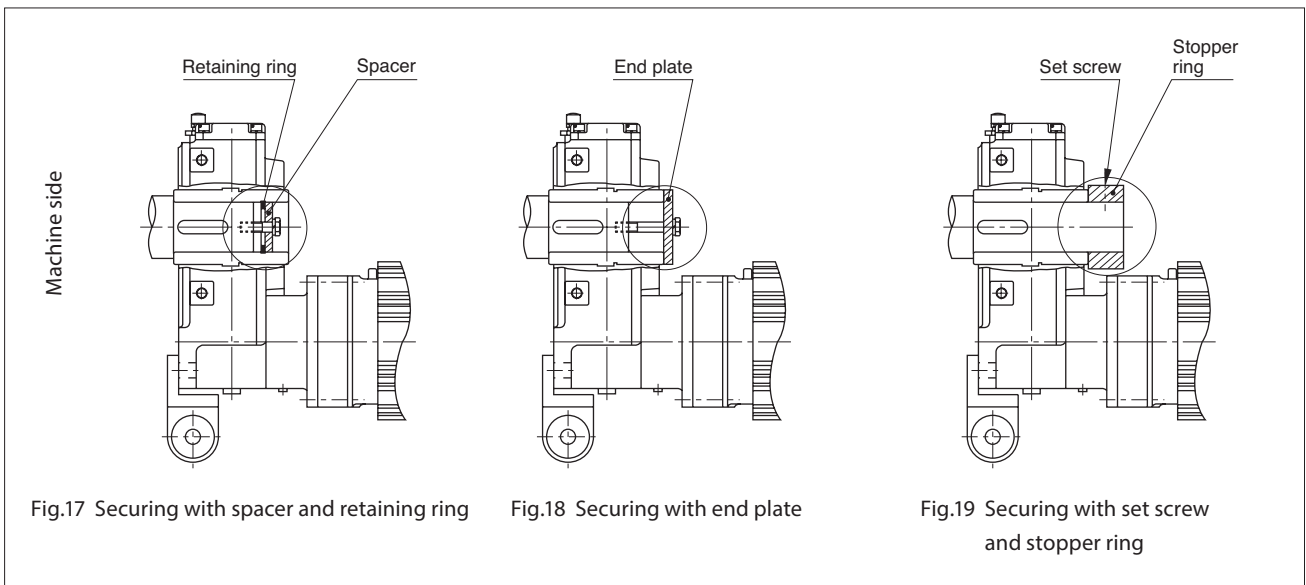



## 5-4 When Using Shrink Disk (Option)

## 5-4-1 Installing the Shrink Disk

- With grease applied to the squeezing surface (before tightening of the boss), the shrink disk is shipped with the reducer, once you receive it, you can assemble it immediately.

The inserts padded between plates can be removed by loosening all the bolts.

If you want to remove and reuse the shrink disk used up to now, first disassemble and clean it, and apply molybdenum disulfide grease to the sliding cone, the tightening bolt, and the surface coming in contact with the bolt head.

- (1) Completely degrease the boss holes and all the shafts coming in contact with them.
- (2) Slide the shrink disk onto the hollow shaft. Do not tighten any tightening bolt until the driven shaft is inserted into the hollow shaft.
- (3) Slide the driven shaft or reducer to insert the driven shaft into the hollow shaft.
- (4) When tightening the bolts, take care to place the surfaces of both plates in parallel. In this case, a wrench with a short grip is suitable for work.
- (5) Make sure that the shrink disk has been placed properly. Then, use a wrench with proper length to start tightening the tightening bolt. Tighten each bolt clockwise (not diagonally) one by one while keeping the two plates in parallel evenly. It is recommended that in this case, each bolt be tightened by 30 degrees at each tightening step.
- (6) After the shrink disk has been tightened, be sure to check the torque by using torque wrench. The specified torque is described on the shrink disk nameplate.
- (7) Last of all, examine whether the two plates are in parallel.

Note: Operate a shrink disk after correctly installed by a process shown above.

No oil lubrication is applied between a hollow shaft and a driven shaft.

It may cause a scratch or a galling to shafts if a shrink disc is rotated without properly installed.

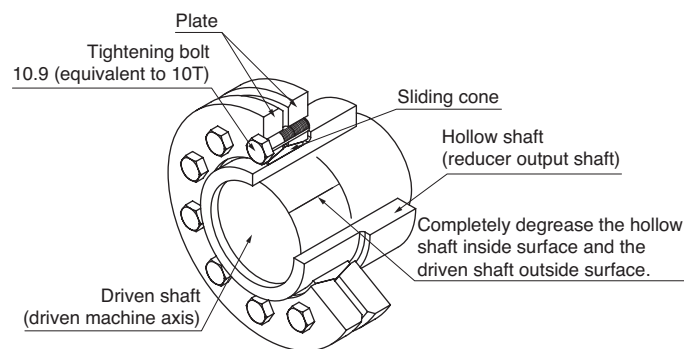

Fig.20 Shrink Disk Construction

## 5-4-2 Removing the Shrink Disk

- To remove the shrink disk, perform the steps of the installation procedure in the reverse order.
- Loosen the bolts little by little in order so that both plates will not slant on the sliding cone.
- Never remove any bolt unless the two plates are in parallel. If this is disobeyed, both plates may pop out suddenly from the sliding cone, resulting in a personal injury. For this reason, loosen all the bolts slightly, and insert a wedge between the plates so that they become parallel.

## 5-5 When Using Taper Grip for Hollow Shaft Type

### 5-5-1 Attachment Procedure of Taper Grip

#### 1. Shaft Preparation Before Attaching the Machine

1-1) Remove all rusts and irregularity (especially protrusion) from the shaft.

1-2) Recommended tolerance of the shaft is "h8"

1-3) Wipe off all dusts and oil with a piece of cloth or alcohols solvent and such.

Take special care to wipe off all traces of oil or grease.

#### 2. Set taper grip on the reducer.

2-1) Apply a thin coat of oil on the screw part at the taper grip.

2-2) Place thrust collar on the screw part of the taper grip.

Insert taper grip into the reducer shaft by clockwise rotation.

Rotate taper grip until the flange touches the thrust collar (Refer to Figure 21).

2-3) Next, rotate the taper grip counter clockwise and match the spot facing hole of the thrust collar and screw hole of the taper grip.

Rough indication of the distance between thrust collar and taper grip flange is about 1 mm (Refer to Figure 22).

Tighten all setting bolts in the taper grip.

Tightening force should be just enough so that the bolt touches the spot facing hole lightly (about the force of hand-tightening the bolt directly).

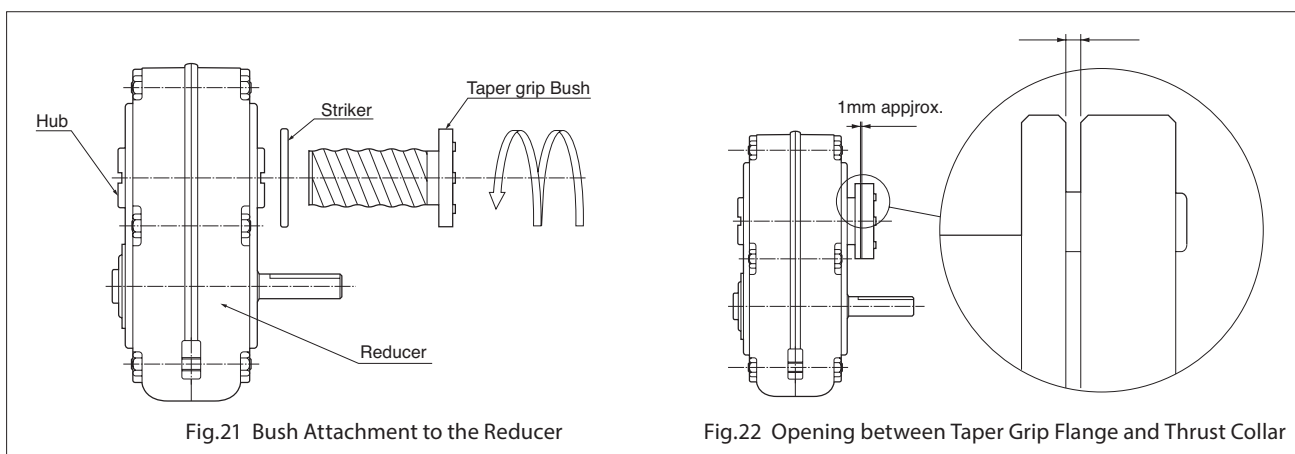

#### 3. Attach the reducer to the mechanical shaft.

3-1) Place reducer (hollow of the taper grip) on the mechanical shaft and insert to the designated position (all the way into reducer dimension L1).

Loosen tightening bolt when it is difficult to insert. Do not pound strongly with hammer, etc.

3-2) Tighten screw of taper grip in the following order.

Always use torque wrench for tightening bolts.

Designated tightening torque of the bolt is as indicated in Table 4 on page16.

1 First, tighten all bolts in the order indicated in Fig.23 (1 → 2 → 3 → 4 → 5 → 6) using 1/3 of the designated tightening torque.

2 Second, tighten all bolts in the same order using 2/3 of the designated tightening torque.

3 Third, tighten all bolts in the same order using the designated tightening torque.

4 Finally, tighten all bolts in the same order a few times using the designated tightening torque.

Now, the attachment is complete.

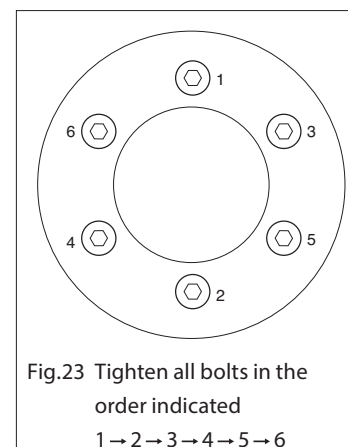

## 4. Additional tightening after operation.

Check the tightening torque 20-30 hours after operation. Tighten again with designated tightening torque when they seem to be loose.

Make sure to check the tightening torque in regularly, such as once every half year.

Table 4-1 Bevel BUDDYBOX

Frame size	Tighten Bolt		Tighten Torque
	Q'ty	Size	N · m
4A10□, 4A11□, 4A12□, 4A14□	6	M12×15	75
4B12□, 4B14□, 4B16□	6	M12×15	140
4C14□, 4C16□, 4C17□	6	M16×20	250
4D16□, 4D17□, 4D18□	6	M16×20	300
4E17□, 4E18□, 4E19□	8	M16×20	300

Table 4-2 Helical BUDDYBOX

Frame size	Tighten Bolt		Tighten Torque
	Q'ty	Size	N · m
Z609□	6	M10×15	31
A610□	6	M12×15	51
B612□	6	M12×15	51
C614□	6	M16×20	128
D616□	6	M16×20	200
E617□	8	M16×20	200

□ is 0, 5, DA, DB, DC.

### 5-5-2 Taper Grip Removal

- Loosen tightening bolt in the designated order slowly until they separate from the thrust collar of the spot facing hole.
- Pound the flange of the taper grip lightly with a wooden or a plastic hammer.  
Now, the reducer is free from the mechanical shaft.
- Tighten two of the tightening screw lightly by hand.  
This is for not locking the taper grip when removing the reducer from the shaft.  
Remove reducer from the mechanical shaft in this condition.  
Use the puller for taper grip flange when removal is difficult.

### 5-5-3 Cautions on Handling Taper Grip

- Never use lubricants containing antifricition composition. It may reduce the designated transmission torque.
- Always use a torque wrench when tightening bolt and apply designated torque in the order indicated in this maintenance manual.  
It may result in reduced transmission torque or loosening otherwise.
- Do not exceed the designated tightening torque.  
It may result in damages of bolt, taper grip, etc.
- Tighten bolts regularly for safety.

- Directions on this manual are for use with **standard three-phase motor made by Sumitomo Drive Technologies** . Use the related motor manual when using **motor with brake** and **motor made by other companies** .

## DANGER

- Do not work on the unit with live wire. Always turn off the power before working on the unit. Otherwise, electric shock may occur.
- Connect following the diagram in shown in the terminal box or maintenance manual. Incorrect wiring may cause electric shock or fire.
- Do not force to bend, pull, or pinch power cable and motor leadwire. Otherwise, it may cause electric shock or fire.
- Make sure to ground the ground terminal. Failure to do so may cause electric shock.
- Follow the standards and regulations for electric facility, extension line, and explosion protection, in addition to maintenance manual. Failure to do so may cause explosion, ignition, electric shock, injury, fire, or damage to the equipment.

## CAUTION

- Conduct wiring following the standards and regulations for electric facility and extension line.
- Motor is not equipped with any protective device. But it is mandatory to attach an overload protector to by electric facility standard. We also recommend installing other protection device such as earth leakage breaker in addition to overload protector.
- Do not touch the terminal when measuring insulation resistance. Electric shock may occur otherwise.
- Use electromagnetic switch on the primary side (3-contact type) when using **star delta starter** . Fire may occur otherwise.
- Use a suppresser filter or reactor on the inverter side, or provide reinforced insulation on the motor side when using a **400V class inverter** to drive the motor. Otherwise, fire or damage may occur by insulation breakdown.
- Always use the specified combination of motor and inverter when driving explosion protection motor with inverter. The approval is only for the specific combination.
- Make sure that there is no explosive atmosphere when measuring insulation resistance for explosion-protection motor. Explosion or ignition may occur when any explosive gas or steam is near the unit.

- Voltage drops when the cable is long. Use cable with sufficient diameter to keep the voltage drop 2% or less.
- Make sure that there is no loose attachment bolt for terminal box after wiring. Then attach terminal cover for **outdoor type and explosion proof type** .

### 6-1 How to Attach and Remove Terminal Cover (for 0.1~0.4kW Three-Phase Motor)

#### (1) Removal

Hold the side of the terminal box as in Fig. 24. Pull off toward yourself. The cover will come off.

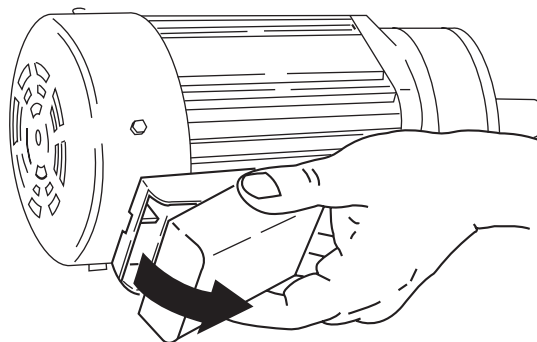

Fig. 24

#### (2) Attachment

Place the terminal box cover on the terminal box casing. Push until the terminal box clicks back into place.



# 6. Wiring

## 6-2 Measurement of insulation resistance

- Always cut off the connection with control board when measuring the insulation resistance for motor. Motor resistance must be measured independently.

Measure the insulation resistance before wiring. Insulation resistance (R) varies by the effect of: Motor output, voltage, type of insulation, coil temperature, humidity, dirt, period of operation, loading duration during test, etc. Minimum value necessary is shown in Table 5.

Table 5 Insulation resistance

Motor voltage	Megohmmeter voltage	Insulation resistance (R)
Low-voltage motor of 600V or less	500V	1M (Ω) or more

Reference: The following equations are shown in JEC-2100.

$$R \geq \frac{\text{Rated voltage (V)}}{\text{Rated output (kW) + 1000}} \quad (\text{M}\Omega)$$

$$R \geq \frac{\text{Rated voltage (V) + Speed (r/min)/3}}{\text{Rated output (kW) + 2000}} \quad +0.5 (\text{M}\Omega)$$

Do not turn the power on when insulation resistance is low. Contact our agent, distributor, or sales office immediately. It may be an insulation failure caused by some reason.

## 6-3 Coordination of System Protection

- (1) Use a molded case circuit breaker for protection from short-circuiting.
- (2) Use an overload protection device. The device should function when the current exceeds rated current value shown on the nameplate.
- (3) Use an overload protection device with higher level for **explosion-proof type motor**. The device should lock within allowable locking time at locking current value shown on the nameplate.

## 6-4 Motor connection

Fig.25 shows the motor connection and the standard specification for terminal codes.

Fig.25 Motor connection and terminal code

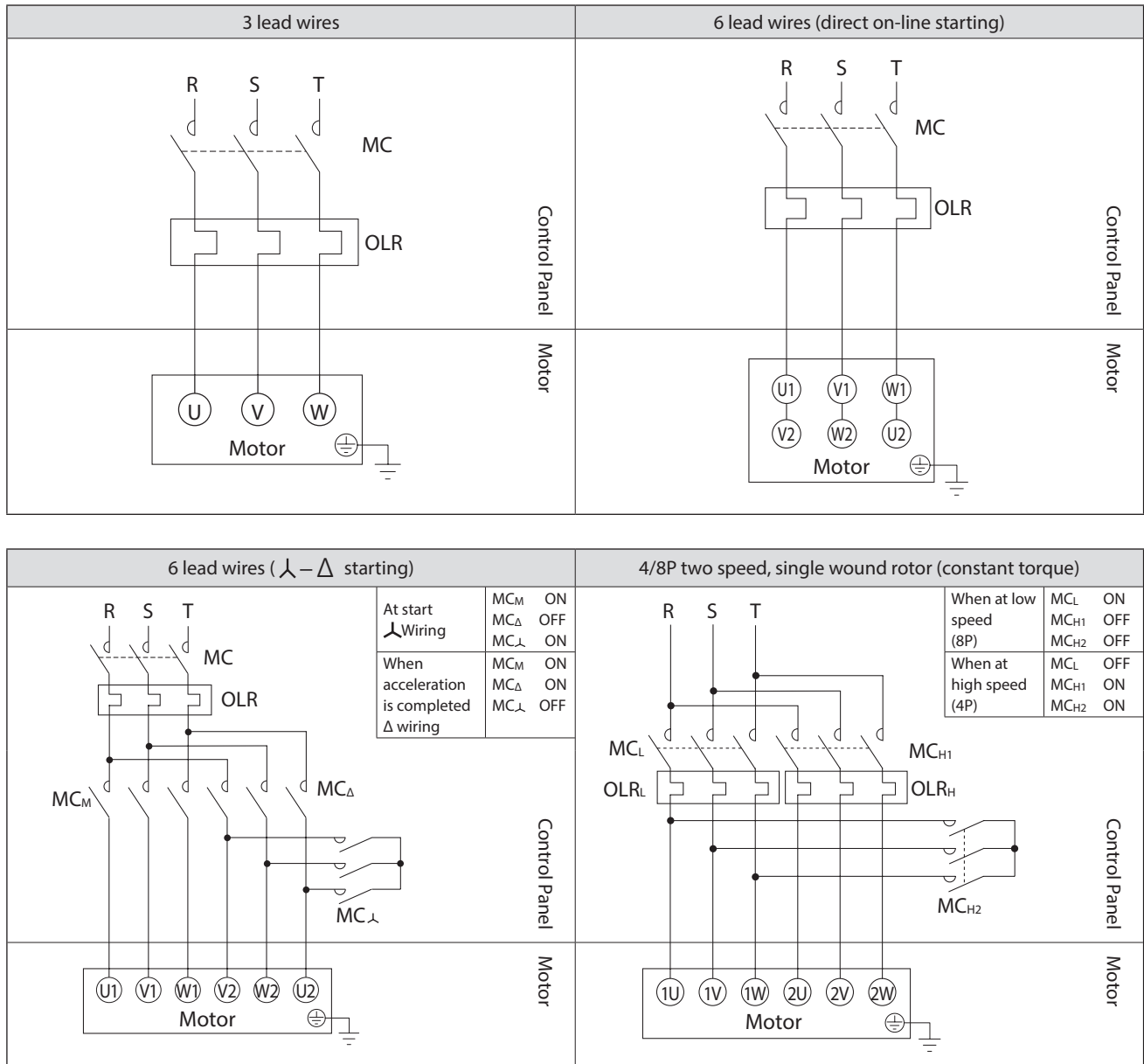

MC: Electromagnetic contactor  
 OLR: Overload protection device or electronic thermal relay } Customer to prepare.

• This diagram shows cases for motors with standard Japanese domestic specifications. Please consult with us for motors with overseas specifications.

## ⚠ DANGER

- Do not go close to or touch the rotating parts (such as output shaft). It may cause injury by getting caught and may result in serious injury or death.
- Turn off the power switch when blackout occurs. Unexpected start may cause electric shock, injury, or damage to the equipment.
- Do not operate the unit without terminal box cover. Attach the cover to the same place after maintenance before operating. Failure to do so may cause electric shock.
- Do not remove the terminal box cover while the power is on. It may cause explosion, ignition, electric shock, injury, fire, or damage to the equipment.

## ⚠ CAUTION

- Do not put finger or any foreign object in the opening of gearmotor and reducer. It may cause electric shock, injury, fire, or damage to the equipment.
- Gearmotor and reducer become very hot during operation. Do not touch with any part of your body. It may cause burns.
- Do not make to oil filler plug loose during operation. It may cause burns by the splash of hot lubrication oil.
- Stop the operation immediately when any abnormality is found. Failure to do so may cause electric shock, injury, or fire.
- Do not operate the unit while exceeding the rated load. It may cause injury or damage to the equipment.

- **Oil-lubricated models** have their oil drained before shipping. Supply recommended lubrication oil before operation.
- Some models need supply of lubrication oil at two places (for output side BUDDYBOX and input side CYCLO).

Check the following before operation when mounting, oil supply, and wiring is complete.

1. Is the wiring correct?
2. Is the coupling with the driven machine correct?
3. Are mounting bolts tightened?
4. Is the rotational direction as planned?
5. Is the level of oil level at the center point of the oil level gauge at stop for oil lubrication models?

Make sure the answer is yes to all of the questions above. Then, start trial run with no load, and apply load gradually. Ask the questions in Table 6 and make corrections during trial run.

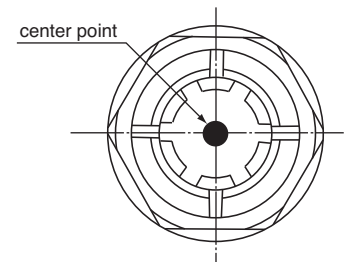

Fig.26 Oil level gauge

Table 6 Checkpoints for Trial Run

When there is abnormal noise or vibration	<ol style="list-style-type: none"> <li>1. Is there any twist in the housing, because the mounting surface is not flat?</li> <li>2. Is there any resonance, because the rigidity of mounting block is insufficient?</li> <li>3. Is there any misalignment with the driven machine?</li> <li>4. Is the vibration of the driven machine transmitted to the gearmotor or reducer?</li> </ol>
When the surface temperature of the gearmotor or reducer is abnormally high	<ol style="list-style-type: none"> <li>1. Is the voltage increase or decrease large?</li> <li>2. Is the ambient temperature too high?</li> <li>3. Is the current exceeding the rated current shown in the nameplate <b>for gearmotors</b> ?</li> </ol>

Stop operation when any abnormality is found. Contact your agent, distributor, or sales office.

## ⚠ DANGER

- Do not handle the unit when cables are live. Be sure to turn off the power; otherwise, electric shock may result.
- Do not touch the rotating parts (such as output shaft) on inspection while operating the machine. It may cause injury by getting caught in the rotating part.
- Do not disassemble or modify **explosion-proof motors**. Explosion, ignition, electric shock, injury, fire, or damage to the equipment may occur.
- The lead-in condition of an **explosion-proof type motor** shall conform to the technical standards for electric facilities, extension regulations and explosion-proofing guide, as well as the maintenance manual; otherwise, explosion, ignition, electric shock, injury, fire or damage to the equipment may result.

## ⚠ CAUTION

- Do not put finger or any foreign object in the opening of gearmotor and reducer. It may cause electric shock, injury, fire, or damage to the equipment.
- Gearmotor and reducer become very hot during operation. Do not touch with bare hands. It may cause burns.
- Never touch the terminals when measuring insulation resistance; otherwise, electric shock may result.
- Do not operate the unit without terminal box cover, which was removed for inspection. Attach the cover to the same place after maintenance before operating. Failure to do so may cause electric shock.
- Following the maintenance manual to make corrections when any abnormality occurs. Do not start operation until the problem is corrected.
- Follow the maintenance manual when replacing lubricant. Always use our recommended oil.
- Do not exchange lubricant while operation or right after the stop. It may cause burns.
- Follow the maintenance manual when supplying or draining grease to motor bearing. Be careful of the rotating body. It may cause injury.
- Do not use gearmotor or reducer that is damaged. Otherwise, it may cause injury or damage to the equipment.
- SDT cannot be responsible for damage or injury caused by products modified by the customer. It exceeds the range of our warranty.
- Discard gearmotor, reducer, and lubricant as an industrial waste following the local and national laws.
- **When driving an explosion-proof type motor with an inverter**, use one inverter for one motor. Use the approved inverter for the motor.

- We recommend overhaul of gearmotor and reducer is after 20,000 hours or 3~5 years of operation. It ensures even longer service life.
- Experience and skill is necessary for overhauling gearmotor and reducers. Contact your agent, distributor, or sales office for overhaul at our specialized factory.

### 8-1 Daily Inspection

Always conduct daily inspection following Table 7. Incorrect inspection may cause troubles.

Table 7 Daily inspection

Inspection item	Details of inspection
Electric current 	Power source value is smaller than the rated current shown in the nameplate.
Noise	There is no abnormal sound or sudden change in noise.
Vibration	There is no abnormally large vibration. There is no sudden change in vibration.
Surface temperature	There is no abnormal temperature rise at the surface. There is no sudden temperature rise. (Temperature rise during operation differs for each model. There is no problem if there is no temperature fluctuation, even if the temperature difference of the surface and ambient condition is about 60°C.)
Oil level (Oil - lubricated mode)	Oil surface is at the bottom side of the overflow hole at stop.
Oil or grease leakage	There is no oil or grease leak from the gear part.
Foundation bolt	Mounting bolt is not loose.
Chain and V - belt	Chain and v-belt is not loose.

When some anomaly is found during the daily inspection, take corrective measures according to section 9. Troubleshooting (pages 35 and 36.) If the anomaly cannot be eliminated, contact our nearest agent, distributor, or sales office.



## 8-2 Lubrication Method

• Always conduct maintenance following related instructions. Incorrect maintenance may cause troubles.

- (1) Refer to Table 8 for method of gear lubrication for you model.
- (2) Table 9 shows location of information for maintenance method for each lubrication type in this manual.
- (3) Bevel BUDDYBOX with Torque Limiter may be unable be referred to below table, so please refer to Page 47.

Table 8 Lubrication Method for Each Gear Type (for Driving at Standard Input Speed)

Frame size	Bevel BUDDYBOX (5 series)	Single stage CYCLO	5Z10□	5Z11□ 5A11□	5Z12□ 5A12□ 5B12□	5A14□ 5B14□ 5C14□	5B16□ 5C16□	5C17□
		Double stage CYCLO	5Z10DA	—	5Z12DA 5Z12DB 5A12DA 5A12DB 5B12DA 5B12DB	5B14DA 5B14DB 5C14DA 5C14DB 5C14DC	5C16DA 5C16DB	—
Output side (Bevel-gear)			Oil bath					
Input side (CYCLO)	Motor: Horizontal		Oil bath					
	Motor: Vertical	Above the output shaft	Oil bath					
		Below the output shaft	Long-life Grease			Grease		

Frame size	Bevel BUDDYBOX (4 series)	Single stage CYCLO	4A10□	4A11□	4A12□ 4B12□	4A14□ 4B14□ 4C14□	4B16□ 4C16□ 4D16□	4C17□ 4D17□ 4E17□	4D18□ 4E18□ 4F18□	4E19□ 4F19□
		Double stage CYCLO	4A10DA	—	4A12DA 4A12DB 4B12DA 4B12DB	4B14DA 4B14DB 4C14DA 4C14DB 4C14DC	4C16DA 4C16DB 4D16DA 4D16DB	4D17DB 4D17DC 4E17DA 4E17DB 4E17DC	4D18DA 4D18DB 4E18DA 4E18DB 4F18DA 4F18DB	4F19DA 4F19DB
Output side (Bevel-gear)			Oil bath							
Input side (CYCLO)	Motor: Horizontal		Oil bath							
	Motor: Vertical	Above the output shaft	Oil bath							
		Below the output shaft	Long-life Grease			Grease				

Frame size	Helical BUDDYBOX	Single stage CYCLO	Z609□	A610□	B612□	—	—	—	C614□	D616□	E617□
		Double stage CYCLO	Z609□DA	A610□DA	B612□DA B612□DB	C614□DA C614□DB	D616□DA D616□DB	E617□DA E617□DB	—	D616□DC	E617□DC
Output side (Bevel or Helical gear)			Oil bath								
Input side (CYCLO)	Motor: Horizontal		Long-life Grease			Grease			Oil bath		
	Motor: Vertical		Long-life Grease			Grease			Grease		

Note: • □ indicates 0 or 5.  
• Consult us for different input speed.

Table 9 Location of Maintenance Information for Each Lubrication Type

Lubrication method	Supply of oil/grease before initial operation after purchase	Pages where maintenance method is shown				
		Oil/grease change period	Recommended oil/grease	Qty of oil/grease	Disposal of oil/grease	
Oil	Self-lubrication	Necessary	8-3 (1) P25	8-3 (2) P25	8-3 (3) P26-28	8-3 (4),(5) P29-31
Grease		Unnecessary	8-4 (1) P31	8-4 (2) P32	8-4 (3) P32-33	8-4 (4) P33

## 8-3 Oil Supply and Change for Gear Part with Oil Lubrication

### (1) Interval Oil Change

Table 10 Oil Change Interval

Task	Change interval	Conditions of use
Supply of oil	At purchase	common
Oil Change	First Change	500 hrs operation or 6 months, whichever comes first.
	Second change and thereafter	5000 hrs operation or 1 year, whichever comes first.
		2500 hrs operation or 6 months, whichever comes first.
		Indoor temperature is 0-35°C Location where temperature cannot be kept at 0-35°C

In the case where the ambient temperature is high, there is intense change in temperature, or the air contains corrosive gas consult the oil producer. These situations may accelerate the deterioration of the oil.

### (2) Recommended Lubricants

Always use recommended lubricants shown in Table 11.

Table 11 Recommended lubricants (Equivalent to SP type industrial extreme-pressure gear oil or JIS K2219)

Ambient temperature °C	COSMO	ENEOS		IDEMITSU	Shell	Mobil		Gulf	CALTEX	bp
-10 to 5	COSMO GEAR SE 68	BONNOC M 68	–	Daphne Super Gear Oil 68	Shell Omala S2 G 68	–	Mobilgear 600 XP 68	Gulf EP Lubricant HD 68	–	Energol GR-XP 68
0 to 35	COSMO GEAR SE 100, 150	BONNOC M 100, 150	BONNOC TS 150	Daphne Super Gear Oil 100, 150	Shell Omala S2 G 100, 150	Spartan EP 150	Mobilgear 600 XP 100, 150	Gulf EP Lubricant HD 100, 150	Meropa 100, 150	Energol GR-XP 100, 150
30 to 50	COSMO GEAR SE 220 - 460	BONNOC M 220 - 460	BONNOC TS 220 - 460	Daphne Super Gear Oil 220-460	Shell Omala S2 G 220 - 460	Spartan EP 220 - 460	Mobilgear 600 XP 220 - 460	Gulf EP Lubricant HD 220 - 460	Meropa 220 - 460	Energol GR-XP 220 - 460

1. Use lubricants with low viscosity for operation during winter or at relatively low ambient temperature.
2. Table 12 shows allowable viscosity of the lubricant. Use the lubricant with viscosity in this range.

Table 12 Allowable viscosities

Min. allowable viscosity	15 mm <sup>2</sup> /s or more at operating oil temperature	Viscosity that ensures oil film strength adequate for load transmission
Max. allowable viscosity	Oil-bath lubrication	4300 mm <sup>2</sup> /s max. Viscosity that permits start-up of Buddybox

3. Make sure that the pour point of the oil is lower than the ambient temperature, at least with 5°C difference. This is for smooth starting.
4. When the range of operating temperature is wide, use oil with high viscosity index. The oil should meet requirements above 2 and 3.
5. Consult us when operating the unit in ambient temperature other than 0-40°C. Parts change and preheat or cooling of lubricant is necessary for some models.

### (3) Amount of Oil Supply

- Table 13 and 14 shows approximate amount of oil.
- Always check the level of oil surface through oil gauge for Bevel BUDDYBOX or overflow plug for helical BUDDYBOX.
- For Bevel BUDDYBOX with Torque Limiter, please refer to Page 46.

Table 13-a Approximate Amount of Oil Supply for Bevel BUDDYBOX (5 series) [L]

Single Stage Type

Output side: Bevel-gear, Input side: CYCLO Drive

G: Grease lubrication (Refer to table 20 on page 30 for amount of grease when refilling.)

Single Stage Type

Frame size	Attachment direction						
	Y1,G1	Y2,G2	Y3,G3	Y4,G4		Y5,G5	Y6,G6
				Output side	Input side		
5Z10□	0.8	1.6	0.8	0.7	G	0.7	0.9
5Z11□	0.9	1.7	0.9			0.7	1.0
5Z12□	0.9	1.8	0.9			0.8	1.0
5A11□	1.6	3.1	1.6	0.8		1.4	1.9
5A12□	1.7	3.2	1.7			1.4	1.9
5A14□	1.9	3.6	1.9			1.7	2.2
5B12□	2.7	5.2	2.7	1.6		2.3	3.1
5B14□	2.9	5.5	2.9			2.5	3.3
5B16□	3.3	6.2	3.3			3.0	3.7
5C14□	5.4	10.7	5.4	3.5		5.1	5.7
5C16□	6.1	11.6	6.1		5.8	6.4	
5C17□	6.5	12.1	6.5		6.2	6.8	

Double Stage Type

Frame size	Attachment direction						
	Y1,G1	Y2,G2	Y3,G3	Y4,G4		Y5,G5	Y6,G6
				Output side	Input side		
5Z10DA	0.9	1.6	0.9	0.7	G	0.9	1.0
5Z12DA	0.9	1.8	0.9			1.1	1.1
5Z12DB	1.0	1.8	1.0			1.1	1.1
5A12DA	1.7	3.2	1.7	0.8		1.4	2.0
5A12DB	1.8	3.2	1.8			1.4	2.0
5B12DA	2.7	5.2	2.7			2.4	3.2
5B12DB	2.8	5.3	2.8	1.6		2.4	3.2
5B14DA	2.9	5.5	2.9			2.6	3.4
5B14DB	3.0	5.5	3.0			2.6	3.4
5C14DA	5.5	10.8	5.5	3.5		5.1	5.7
5C14DB	5.5	10.8	5.5		5.2	5.7	
5C14DC	5.5	10.9	5.5		5.2	5.8	
5C16DA	6.1	11.6	6.1		5.9	6.5	
5C16DB	6.2	11.7	6.2		6.0	6.5	

Note: □ shows number 0 or 5.

# 8. Daily inspection and Maintenance Common

Table 13-b Approximate Amount of Oil Supply for Bevel BUDDYBOX (4 series) [L]

Single Stage Type

Output side: Bevel-gear, Input side: CYCLO Drive

G: Grease lubrication (Refer to table 20 on page 30 for amount of grease when refilling.)

Frame size	Attachment direction						
	Y1,F1,G1, K1,V1	Y2,F2,G2, K2,V2,W2	Y3,F3,G3, K3,V3,W3	Y4,F4,G4,K4,W4		Y5,F5,G5, K5,V5	Y6,F6,G6, K6,V6
				Output side	Input side		
4A10□	1.6	3.2	1.6	1.1	G	1.4	1.8
4A11□	1.7	3.3	1.7			1.4	1.9
4A12□	1.7	3.4	1.7			1.5	1.9
4A14□	1.9	3.8	1.9			1.7	2.1
4B12□	3.3	6.5	3.3	1.7		3.3	3.2
4B14□	3.5	7.0	3.5			3.5	3.4
4B16□	3.9	7.6	3.9			4.0	3.9
4C14□	5.5	11.1	5.5	2.7		5.3	5.9
4C16□	6.0	11.8	6.0			5.7	6.3
4C17□	6.3	12.5	6.3			6.1	6.7
4D16□	10.1	19.9	10.1	4.6		9.7	10.4
4D17□	10.4	20.5	10.4			10.0	10.8
4D18□	10.7	21.0	10.7		10.3	11.1	
4E17□	14.6	28.8	14.6	6.3	13.1	16.1	
4E18□	14.7	29.1	14.7		13.2	16.2	
4E19□	15.7	30.4	15.7		14.2	17.2	
4F18□	20.0	39.4	20.0	7.3	18.5	21.4	
4F19□	20.8	40.6	20.8		19.3	22.2	

Note: □ shows number 0 or 5.

Double Stage Type

Output side: Bevel-gear, Input side: CYCLO Drive

G: Grease lubrication (Refer to table 20 on page 30 for amount of grease when refilling.)

Frame size	Attachment direction						
	Y1,F1,G1, K1,V1	Y2,F2,G2, K2,V2,W2	Y3,F3,G3, K3,V3,W3	Y4,F4,G4,K4,W4		Y5,F5,G5, K5,V5	Y6,F6,G6, K6,V6
				Output side	Input side		
4A10DA	1.7	3.2	1.7	1.1	G	1.4	1.9
4A12DA	1.7	3.4	1.7			1.5	2.0
4A12DB	1.8	3.4	1.8			1.5	2.0
4B12DA	3.3	6.5	3.3	1.7		3.4	3.3
4B12DB	3.4	6.6	3.4			3.4	3.3
4B14DA	3.5	7.0	3.5			3.6	3.5
4B14DB	3.6	7.0	3.6	3.6		3.5	
4C14DA	5.6	11.2	5.6	2.7		5.3	5.9
4C14DB	5.6	11.2	5.6			5.4	5.9
4C14DC	5.6	11.3	5.6			5.4	6.0
4C16DA	6.0	11.8	6.0	4.6		5.8	6.4
4C16DB	6.1	11.9	6.1			5.9	6.4
4D16DA	10.1	20.0	10.1		4.6	9.8	10.5
4D16DB	10.1	20.0	10.1	9.8		10.5	
4D17DA	10.2	20.0	10.2	4.6		9.8	10.6
4D17DB	10.5	20.6	10.5			10.2	10.9
4D17DC	10.7	20.7	10.7			10.3	11.0
4D18DA	10.8	21.1	10.8	6.3		10.5	11.2
4D18DB	11.7	21.4	11.7		11.4	12.1	
4E17DA	14.6	28.8	14.6		6.3	13.1	16.1
4E17DB	14.7	28.9	14.7	13.2		16.2	
4E17DC	14.8	29.0	14.8	13.3		16.3	
4E18DA	14.8	29.3	14.8	6.3	13.3	16.3	
4E18DB	15.7	29.6	15.7		14.2	17.2	
4E19DA	17.5	31.0	17.5		16.0	19.0	
4E19DB	17.7	31.0	17.7	16.2	19.2		
4F18DA	20.1	39.6	20.1	7.3	18.6	21.5	
4F18DB	21.0	39.9	21.0		19.5	22.4	
4F19DA	22.6	41.2	22.6		21.1	24.0	
4F19DB	22.8	41.2	22.8		21.3	24.2	

Table 14 Approximate Amount of Oil Supply for Helical BUDDYBOX [L]

Single Stage Type

Output side: Helical-gear, Input side: CYCLO Drive

G: Grease lubrication (Refer to Table 21 on page 31 for amount of grease when refilling.)

		Y1	Y2	Y3	Y4	Y5	Y6
Z609□	Output side	0.6	0.6	0.5	0.6	1.1	1.0
	Input side	G	G	G	G	G	G
Z610□	Output side	0.8	0.9	0.7	0.9	1.5	1.4
	Input side	G	G	G	G	G	G
B612□	Output side	1.0	1.5	1.0	1.5	2.0	1.8
	Input side	G	G	G	G	G	G
C614□	Output side	1.7	2.1	1.3	2.1	4.7	3.5
	Input side	0.4	0.4	0.4	0.4	G	G
D616□	Output side	2.7	3.5	2.0	3.5	7.0	5.5
	Input side	0.7	0.7	0.7	0.7	G	G
E617□	Output side	3.5	4.2	2.5	4.2	9.0	7.0
	Input side	0.9	0.9	0.9	0.9	G	G

Note: □ shows number 0 or 5.

Double Stage Type

Output side: Helical-gear, Input side: CYCLO Drive

G: Grease lubrication (Refer to Table 21 on page 31 for amount of grease when refilling.)

	Attachment direction											
	Y1		Y2		Y3		Y4		Y5		Y6	
	Output side	Input side	Output side	Input side	Output side	Input side	Output side	Input side	Output side	Input side	Output side	Input side
Z609□DA	0.6	G	0.6	G	0.5	G	0.6	G	1.1	G	1.0	G
A610□DA	0.8	G	0.9	G	0.7	G	0.9	G	1.5	G	1.4	G
B612□DA	1.0	G	1.5	G	1.0	G	1.5	G	2.0	G	1.8	G
B612□DB		G		G		G		G				
C614□DA	1.7	G	2.1	G	1.3	G	2.1	G	4.7	G	3.5	G
C614□DB		G		G		G		G				
D616□DA	2.7	G	3.5	G	2.0	G	3.5	G	7.0	G	5.5	G
D616□DB		G		G		G		G				
D616□DC		1.4		1.4		1.4		1.4				
E617□DA	3.5	G	4.2	G	2.5	G	4.2	G	9.0	G	7.0	G
E617□DB		G		G		G		G				
E617□DC		1.4		1.4		1.4		1.4				

Note: □ shows number 0 or 5.

## (4) Oil supply and discharge

### Bevel BUDDYBOX 5 & 4 Series (Except Y2, F2, G2, K2, V2, W2)

- Oil supply
  - 1 Remove the air-vent plug on oil supply port.
  - 2 Supply oil on the oil supply port while checking the level of oil surface through the oil level gauge.
  - 3 Make sure that the level of oil surface is at the middle of oil level gauge after it has settled.
  - 4 Attach the air-vent plug to oil supply port.
  - 5 When air-vent plug is attached, check the seal washer set and the cap of air-vent plug closed steady.  
(Check the cap of air-vent plug regularly because ti may loosen by vibration)
- Oil discharge
  - 1 Remove the drain plug to discharge oil.
  - 2 When the drain plug is attached, check the seal washer set.

[Locations example of oil supply / discharge ports]

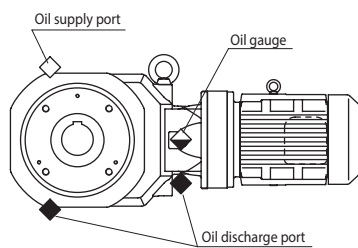

Bevel BUDDYBOX  
LHYM-Y1 (5 Series)

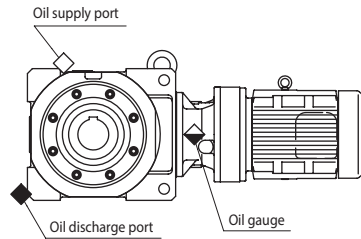

Bevel BUDDYBOX  
LHYM-Y1 (4 Series)

[Detail of oil supply port]

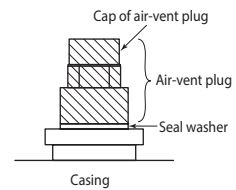

### Bevel BUDDYBOX 5 & 4 Series (Y2, F2, G2, K2, V2, W2)

- Oil supply
  - 1 Remove the air-vent plug and oil fill cup lid on oil supply port A. (The air-vent plug and oil fill cup lid do not needed to be separated)
  - 2 Supply oil on the oil supply port A while checking the level of oil surface through the oil level gauge.
    - Bevel BUDDYBOX 4Series can be shorter oil filling time with using both oil supply port B.
    - At first remove the plug on oil supply port B, and supply oil into the output side gear casing. After checking that inside of output side gear casing is filled with oil, attach the plug to oil supply port B. When the drain plug is attached, check the seal washer set.
    - Next, supply oil on oil supply port A to fill with oil in input side gear casing.
  - 3 Make sure that the level of oil surface is at the middle of oil level gauge after it has settled.
  - 4 Attach the air-vent plug and oil fill cup lid to oil filler.
  - 5 When air-vent plug and oil filler cup lid are attached, check the seal washer set and the cap of air-vent plug closed steady.  
(Check the cap of air-vent plug regularly because ti may loosen by vibration)
- Oil discharge
  - 1 Remove the drain plug to discharge oil.
  - 2 When the drain plug is attached, check the seal washer set.

[Locations example of oil supply / discharge ports]

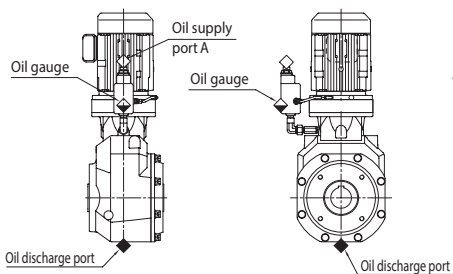

Bevel BUDDYBOX  
LHYM-Y2 (5 Series)

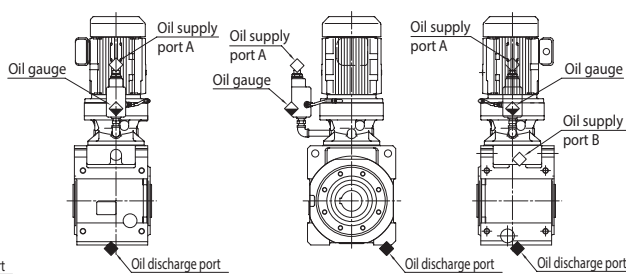

Bevel BUDDYBOX  
LHYM-Y2 (4 Series)

[Detail of oil supply port]

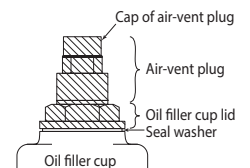

## Helical BUDDYBOX

## ● Oil supply

- 1 Remove the air-vent plug on oil supply port. (Supplying oil on 2 ports will need by some models.)
- 2 Supply oil on the oil supply port while checking the level of oil surface through the oil level gauge.
- 3 Make sure that the level of oil surface is at the middle of oil level gauge after it has settled.
- 4 Attach the air-vent plug to oil supply port.

## ● Oil discharge

- 1 Remove the drain plug to discharge oil.
- 2 In the case of Helical BUDDYBOX and frame size is Z6090-C6145, remove both of 2 drain plugs on oil discharge port to discharge oil.

[Locations example of oil supply / discharge ports]

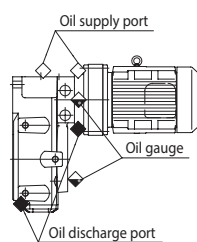

Helical BUDDYBOX  
EHYM-Y1

[Detail of oil supply port]

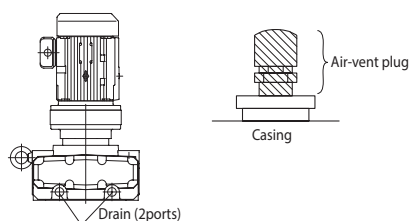

Helical BUDDYBOX  
Z6090~C6145-Y5

- Always stop the unit while supplying oil.
- It may take some time for the oil surface to settle when the oil viscosity is high.
- Supply oil up to the middle of oil level gauge.
- Oil level may drop during operation because the air in inside of reducer come out during operation. Do check oil level after test operation. Supply oil in the case that oil level become low.
- Take a pause for a while to check oil level after stopping operation. It can not check oil level during operation or right after stopping.

## (5) Long-term stoppage

Table 15 Long-term stoppage

Stoppage period	Approx. 1 month	Change the oil and operate the unit for several minutes before stopping the unit.
	More than 1 month	Flush the unit, supply rust-preventive oil, and operate the unit without a load for several minutes before stopping the unit.

• Always replace old oil with new oil when re-operating after long-term stoppage. The old oil may have deteriorated.

## 8-4 Grease Supply and Replacement of Grease Lubricated Input Side (CYCLO Part)

### (1) Grease Refill and Replacement Timing

Table 16 Timing of Supply and Replacement of Grease

(Other than Long-life types)

Model	Grease and Supply and Replacement Interval
Grease-lubricated (Long-life type) models ( section in Table 8 on page 24)	These models are filled with long-life grease, BEN10-No.2. This enables operation for extended periods without supplying. However, oil replacement after every 20,000 hours or 3 to 5 years by disassembling the unit will ensure longer lifetime.
Grease-lubricated models other than long-life type	Refer to Tables 17 and 18 for supply and change of grease.

Table 17 Timing of Grease Supply

(Other than Long-life types)

Hours of operation	Replenishment interval	Remarks
10 hr max./day	3 – 6 months	Shorten the supply interval when the operating conditions are severe or the frame size is large.
10 – 24 hr/day	500 – 1000 hrs	

Table 18 Timing of Grease Replacement

(Other than Long-life types)

Change interval	Remarks
Every 20,000 hrs or 3 – 5 years	Shorten the supply interval when the operating conditions are severe or the frame size is large.



## (2) Recommended grease

Table 19 Recommended grease

Model	Mounting position	Frame size	Type	Manufacturer	Description	Ambient temperature	
Bevel BUDDYBOX 4 Series	Y4, F4, G4, K4, W4	4A10□, 4A11□, 4A12□ 4B12□	Long-life Grease	NIPPECO	BEN10-No.2	-10 to 50°C	
		4A14□ 4B14□, 4B16□ 4C14□, 4C16□, 4C17□ 4D16□, 4D17□, 4D18□ 4E17□, 4E18□, 4E19□ 4F18□, 4F19□	Grease	COSMO	COSMO GREASE DYNAMAX SH No.2		
Bevel BUDDYBOX 5 Series	Y4, G4	5Z10□, 5Z11□, 5Z12□ 5A11□, 5A12□ 5B12□	Long-life Grease	NIPPECO	BEN10-No.2	-10 to 50°C	
		5A14□ 5B14□, 5B16□ 5C14□, 5C16□, 5C17□	Grease	COSMO	COSMO GREASE DYNAMAX SH No.2		
Helical BUDDYBOX	Y1, Y2 Y3, Y4 F1, F2 F3, F4	Reduction ratio 11-18	Z6090, Z6095 A6100, A6105 B6120, B6125	Long-life Grease	Shell	Shell Alvania EP Grease R0	-10 to 40°C
	All	Reduction ratio 21-4365	Z609□, A610□, B612□	Long-life Grease	NIPPECO	BEN10-No.2	-10 to 50°C
			C614DA, C614DB D616DA, D616DB, D616DC E617DA, E617DB, E617DC	Grease	COSMO	COSMO GREASE DYNAMAX SH No.2	
Y5, Y6 F6, F6		C6140, C6145 D6160, D6165 E6170, E6175	Grease	COSMO	COSMO GREASE DYNAMAX SH No.2		

Note: □ shows "0", "5", "DA", "DB" or "DC".

- Do not use grease other than the ones shown in Table 19.
- Consult us when operating the unit in ambient temperature other than 0-40°C constantly. Special models may be necessary.

## (3) Amount of Grease for Supply and Replacement

Table 20 and 21 shows amount of oil to apply. Sufficient amount of grease for each supply is about 1/3~1/2 of the reduction part.

Table 20 Approximate Amount of Grease Supply for Bevel BUDDYBOX [g]

### BBB 5-Series

#### Single Stage Type

Size	Mounting Direction
	Y4,G4
5Z10□	
5Z11□	
5Z12□	
5A11□	
5A12□	
5A14□	150~225
5B12□	
5B14□	150~225
5B16□	250~375
5C14□	150~225
5C16□	250~375
5C17□	335~500

#### Double Stage Type

Size	Mounting Direction
	Y4,G4
5Z10DA	
5Z12DA	
5Z12DB	
5A12DA	
5A12DB	
5B12DA	
5B12DB	
5B14DA	8.5~12.5
5B14DB	20~30
5C14DA	8.5~12.5
5C14DB	20~30
5C14DC	40~60
5C16DA	20~30
5C16DB	40~60

### BBB 4-Series

#### Single Stage Type

Size	Mounting Direction
	Y4,F4,G4 K4,W4
4A10□	
4A11□	
4A12□	
4A14□	150~225
4B12□	
4B14□	150~225
4B16□	250~375
4C14□	150~225
4C16□	250~375
4C17□	335~500
4D16□	250~375
4D17□	335~500
4D18□	370~550
4E17□	335~500
4E18□	370~550
4E19□	500~750
4F18□	370~550
4F19□	500~750

#### Double Stage Type

Size	Mounting Direction	Size	Mounting Direction
	Y4,F4,G4 K4,W4		Y4,F4,G4 K4,W4
4A10DA		4D17DB	40~60
4A12DA		4D17DC	85~125
4A12DB		4D18DA	40~60
4B12DA		4D18DB	150~225
4B12DB		4E17DA	20~30
4B14DA	8.5~12.5	4E17DB	40~60
4B14DB	20~30	4E17DC	85~125
4C14DA	8.5~12.5	4E18DA	40~60
4C14DB	20~30	4E18DB	150~225
4C14DC	40~60	4E19DA	110~165
4C16DA	20~30	4E19DB	150~225
4C16DB	40~60	4F18DA	40~60
4D16DA	20~30	4F18DB	150~225
4D16DB	40~60	4F19DA	110~165
4D17DA	20~30	4F19DB	150~225

- Note:
- Because shaded section indicates Long-life grease models, they do not need to supply grease.
  - □ indicates either 0 or 5.
  - Refer to page 26-28 for approximate amount of oil supply for the part of oil lubrication.

Table 21 Approximate Amount of Grease Supply for Helical BUDDYBOX [g]  
Single Stage Type                      Double Stage Type

Size	Mounting Direction		Size	Mounting Direction
	Y1,Y2,Y3,Y4	Y5,Y6		All of Direction
	Input Side	Input Side		Input Side
Z609□			Z609DA	
A610□			A610DA	
B612□			B612DA	
C614□		B612DB	C614DA	
D616□			C614DB	20~30
E617□				D616DA
		Oil Lubrication		D616DB
			D616DC	85~125
		150~225	E617DA	20~30
		250~375	E617DB	40~60
		335~500	E617DC	85~125

Note: • Because shaded section  indicates Long-life grease models, they do not need to supply grease.  
 • □ indicates either 0 or 5.  
 • Refer to page 26-28 for approximate amount of oil supply for the part of oil lubrication.

#### (4) Procedure for Supplying and Draining of Grease

Procedure for supplying grease for **grease-lubricated models** (excl. maintenance-free type)

- 1 Remove the grease discharge plug from the outside cover.
- 2 Supply grease with a grease gun from the grease nipple in the inside cover section or motor connection cover.
- 3 Attach the grease discharge plug.

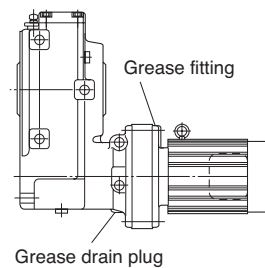

Fig.27 Position of Grease Drain Plug (Example: EHYM Type)

- Supply grease during operation to ensure proper, uniform circulation.
- Supply grease slowly.
- Do not supply grease more than the amount shown in Table 20 and 21. Grease temperature rise or grease leakage to motor part because of agitation heat.

#### Grease Replacement of Grease-Lubricated and Maintenance-Free Models

- The unit may be used for a long time safely, because long-lifetime grease is sealed in. However, overhaul every 20,000 hours or 3-5 years of operation ensures even longer lifetime.
- Always consult our specialized factory for overhaul of gearmotors and reducers. Experience is necessary for overhaul.

Whenever abnormality occurs in gearmotors or reducers, take sufficient measure immediately referring to Table 22 and 23. Consult our nearest distributor or sales office when the unit does not recover after taking the measure.

Table 22 Troubleshooting

Problem		Possible cause	Measure	
The motor will not operate under load.		Power failure	Contact the electric power company.	
		Defective electric circuit	Check the circuit.	
		Blown fuse	Replace the fuse with a new one.	
		Protective device is engaged	Disengage protective device.	
		Load locking	Check the load and safety device.	
		Poor switch contact	Adjust the contact area section.	
		Disconnection of motor stator coil	Return the unit to factory for servicing.	
		Bearing is broken	Return the unit to factory for servicing.	
		3-phase is functioning as single-phase.	Check the power supply with a voltmeter. Check the motor, coil in the transformer, contactor, fuse, etc. and repair or replace them.	
The motor runs without a load but the output shaft does not rotate.		Damage due to overloading of gears	Return the unit to factory for servicing.	
The output shaft turns without a load	When a load is applied	The switch is heated.	Insufficient capacity of switch	Replace the switch with a specified one.
			Overload	Decrease the load to the specified value.
		Fuse tripping	Insufficient capacity of fuse	Replace the fuse with a specified one.
			Overload	Decrease the load to the specified value.
		The speed will not increase and the motor is overheating.	Voltage drop	Contact the electric power company.
			Overload	Decrease the load to the specified value.
	Short-circuited motor stator coil		Return the unit to factory for servicing.	
	The motor stops.	The key is missing	Install a key.	
		The bearing is burned.	Return the unit to factory for servicing.	
		Poor adjustment of protective device	Adjust the protective device.	
	The motor runs in the reverse direction.		Connection error	Change the connection.
	Fuse tripping		The outlet wire is short-circuited.	Return the unit to factory for servicing.
Poor contact between motor and starter			Complete the connection.	
Excessive temperature rise		Overload	Decrease the load to the specified value.	
		Voltage drop or voltage rise	Contact the electric power company.	
		The ambient temperature is high.	Improve the ventilation method.	
		Damaged bearing or gear	Return the unit to factory for servicing.	
Oil leakage	Leakage of oil/grease from input/output shaft section		Damaged oil seal	Return the unit to factory for servicing.
	Leakage of oil/grease from the contact surfaces of frame and outside cover		Loose bolts	Tighten bolts correctly.
	Leakage of oil/grease into motor		Damaged oil seal	Replace the oil seal with a new one.
			Excessive oil/grease supply	Remove excess oil/grease.
Abnormal sound Abnormal vibration		Entry of dust and foreign matter into bearings or damaged bearings.	Return the unit to factory for servicing.	
		Damaged gear.	Return the unit to factory for servicing.	
		Distortion of housing because the installation surface is not flat	Make the installation base flat or make adjustment using shims.	
		Resonance due to insufficient rigidity of installation base	Reinforce the installation base to increase rigidity.	
		Nonalignment of shaft with driven machine	Align the shaft centers.	
		Transmission of vibration from the driven machine	Individually operate the gearmotor or reducer to check the source of the sound.	
Abnormal sound from motor		Entry of foreign matter	Remove the foreign matter.	
		Damaged bearings	Return the unit to factory for servicing.	

Table 23 Troubleshooting

	Problem	Possible cause	Correction
Inverter tripping	Shut-off due to overcurrent	Sudden acceleration/deceleration	Make the acceleration/deceleration time longer.
		Sudden change in load	Decrease the load change.
	Grounding overcurrent	Grounding on the output side	Make correction to eliminate grounding.
	DC overcurrent	Short-circuiting on the output side	Make correction to eliminate short-circuiting. Check cables.
	Shut-off due to regenerative overvoltage	Sudden deceleration	Make the deceleration time longer. Reduce the braking frequency.
	Thermal relay operation	Overloading	Decrease the load to the specified value.

10-1 Construction Drawing of Gear part

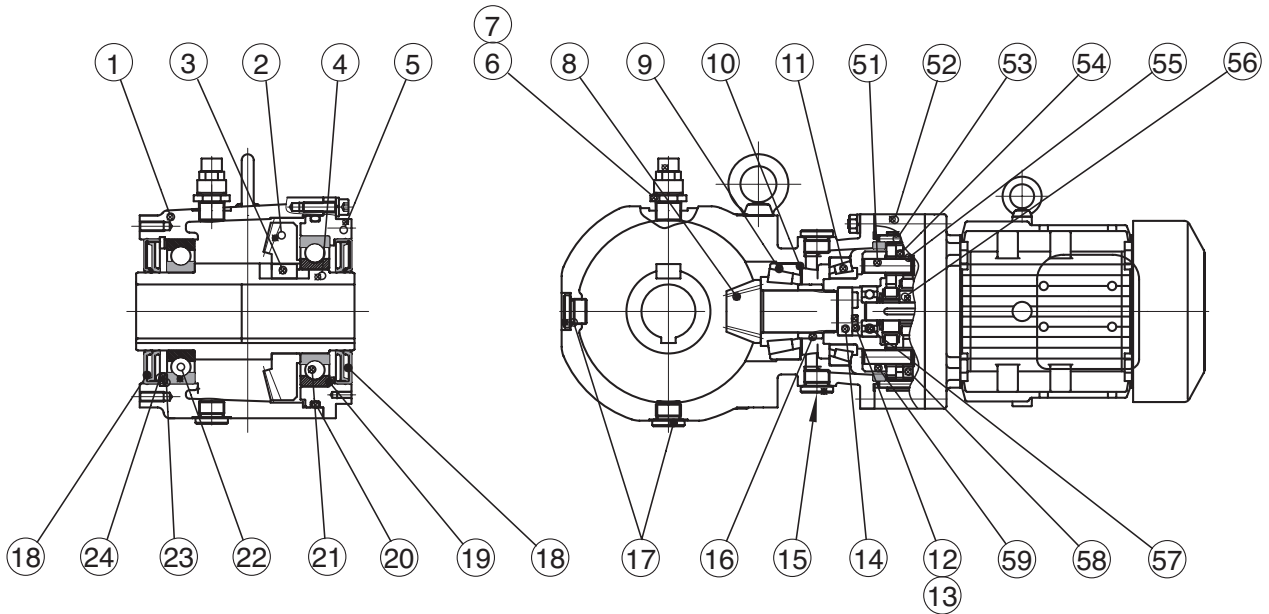

Fig.28 LHYM1-5Z115-Y1 (5 Series)

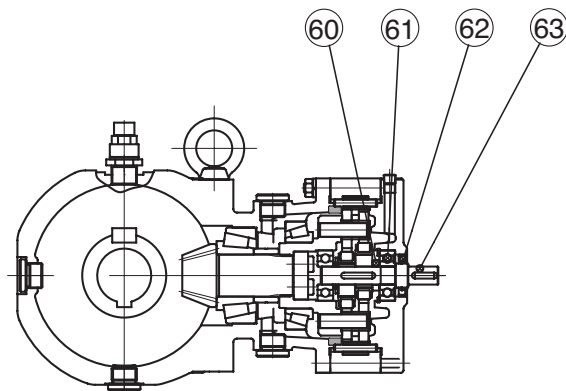

Fig.29 LHY-5Z115-Y1 (5 Series)

Table 24 Main parts of Bevel Buddybox gears (5 Series)

No.	Part name	No.	Part name	No.	Part name
1	Casing	14	End plate	51	Pin carrier pin
2	Gear	15	Hexagon socket head bolt	52	Ring gear housing
3	Rectangular parallel key	16	Collar	53	Ring gear pin
4	Hollow shaft	17	Hexagon socket head bolt	54	Spacer ring
5	Cover	18	Oil seal	55	Pin carrier roller
6	Bush	19	Shim	56	Eccentric bearing
7	Air vent	20	O-ring	57	Cycloid disc
8	Pinion shaft	21	Output shaft A bearing	58	Pin carrier
9	Pinion shaft A bearing	22	Output shaft B bearing	59	Input shaft A bearing
10	Shim	23	Shim	60	Spacer
11	Pinion shaft B bearing	24	retaining ring	61	Input shaft B bearing
12	Hexagon head bolt			62	Oil seal
13	Spring washer			63	Input shaft

Parts No.21,22 : Output shaft bearing A,B of size Z are boll bearings, and them of other size are roller bearings.

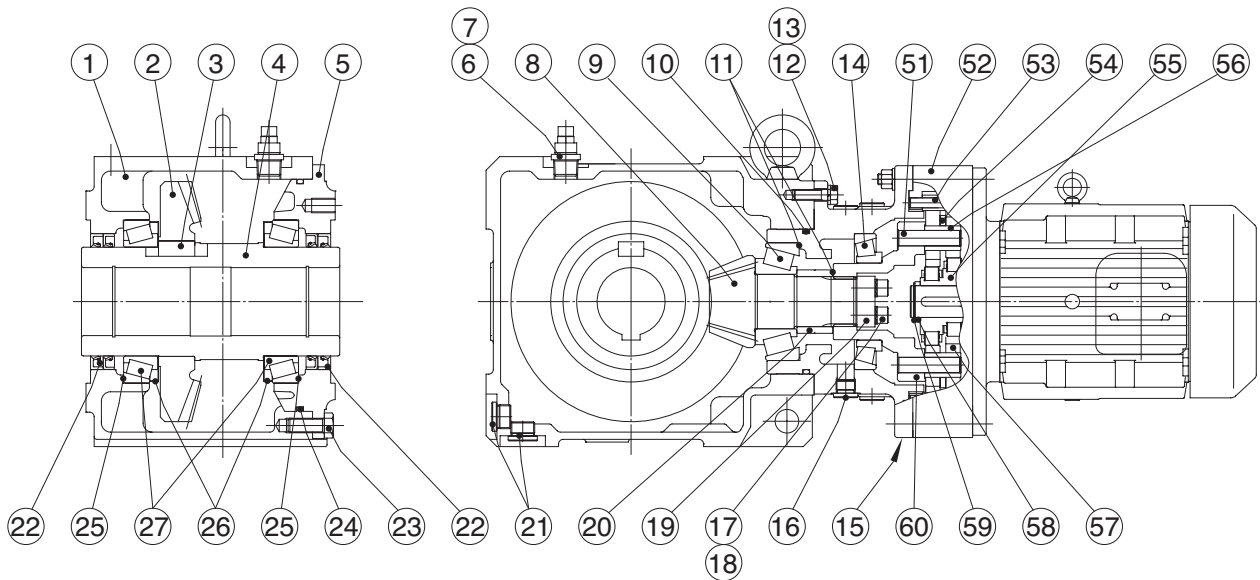

Fig. 30 LHYM3-4C145 (4 series)

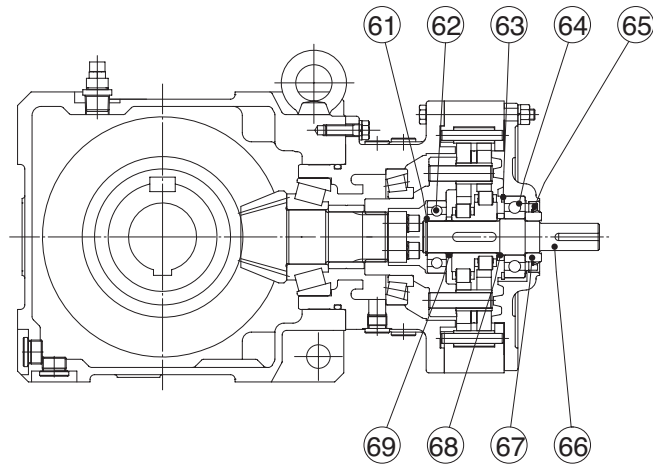

Fig. 31 LHY-4C145 (4 series)

Table 24 Main parts of Bevel Buddybox gears

No.	Part name	No.	Part name	No.	Part name	No.	Part name
1	Casing	16	Hexagon socket head plug (brimmed)	51	Pin carrier pin	66	High speed shaft
2	Gear	17	Hexagon socket head bolt	52	Ring gear housing	67	Collar
3	Rectangular parallel key	18	Spring washer	53	Ring gear pin	68	Spacer
4	Hollow shaft	19	End plate	54	Spacer ring	69	Spacer
5	Cover	20	Collar	55	Eccentric bearing		
6	Bush	21	Hexagon socket head plug (brimmed)	56	Pin carrier roller		
7	Air vent	22	Oil seal	57	Cycloid disc		
8	Pinion shaft	23	Hexagon head bolt	58	Spacer		
9	Pinion shaft A bearing	24	O-ring	59	External retaining ring		
10	O-ring	25	Shim	60	Pin carrier		
11	Shim	26	Nilosring	61	External retaining ring		
12	Hexagon head bolt	27	Output shaft bearing	62	High speed shaft A bearing		
13	Spring washer			63	External retaining ring		
14	Pinion shaft B bearing			64	High speed shaft B bearing		
15	Flanged casing			65	Oil seal		

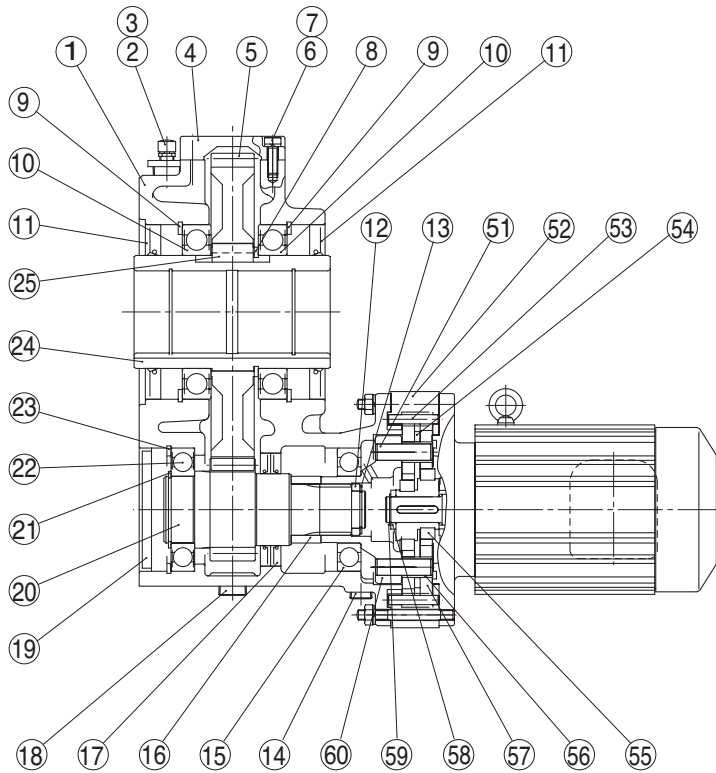

Fig. 32 EHYM3-C6145

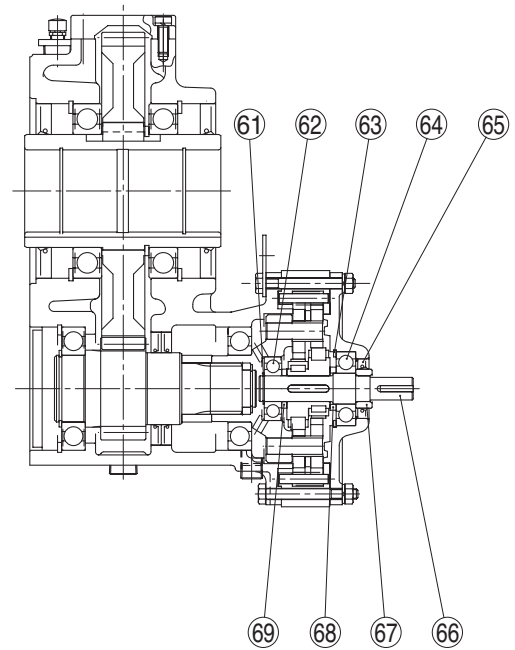

Fig. 33 EHY-C6145

Table 26 Main parts of Helical Buddybox gears

No.	Part name	No.	Part name	No.	Part name	No.	Part name
1	Casing	14	Hexagon socket head plug	51	Pin carrier pin	64	High speed shaft B bearing
2	Bush	15	Pinion shaft B bearing	52	Ring gear housing	65	Oil seal
3	Air vent	16	Pinion shaft spacer	53	Ring gear pin	66	High speed shaft
4	Cover	17	Oil seal	54	Spacer ring	67	Collar
5	Gear	18	Hexagon socket head plug	55	Eccentric bearing	68	Spacer
6	Hexagon head bolt	19	Seal cap	56	Pin carrier roller	69	Spacer
7	Spring washer	20	Pinion shaft	57	Cycloid disc		
8	External retaining ring	21	External retaining ring	58	Spacer		
9	Internal retaining ring	22	Pinion shaft A bearing	59	External retaining ring		
10	Output shaft bearing	23	Internal retaining ring	60	Pin carrier		
11	Oil seal	24	Hollow shaft	61	External retaining ring		
12	Spacer	25	Rectangular parallel key	62	High speed shaft A bearing		
13	External retaining ring			63	Internal retaining ring		

## 10-2 Construction Drawing of Motor part (for direct coupling with CYCLO drive)

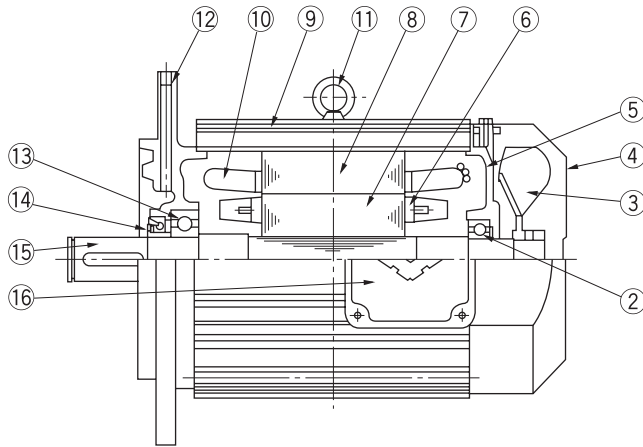

Fig. 34 Construction Example of Frame Size 80-112M

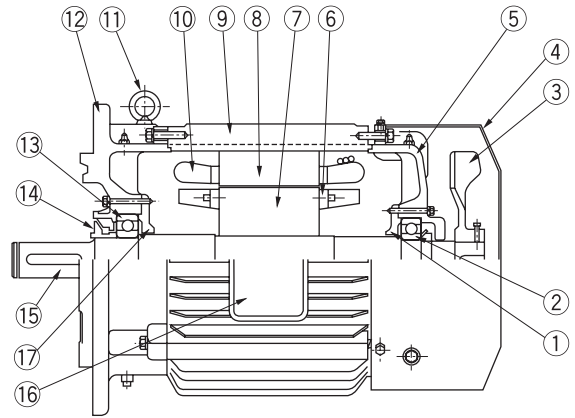

Fig. 35 Construction Example of Frame Size 180 and Longer

Table 27 Main parts of motor

No.	Part name	No.	Part name	No.	Part name
1	Bearing cover	7	Rotor core	13	Motor shaft bearing A
2	Motor shaft bearing B	8	Stationary core	14	Oil seal
3	Fan	9	Stator frame	15	Motor shaft
4	Fan cover	10	Stator windings	16	Conduit box
5	End bracket	11	Eyebolt	17	Bearing cover
6	Rotor conductor short circuit ring	12	Cyclo flange bracket		



## Application Product

# BUDDYBOX<sup>®</sup> with Torque Limiter

This manual covers the torque limiter unit.

For information on handling the reducer unit and the motor unit see P1 – 39.

### Contents

11. Wiring .....	42
12. Adjusting Preset Torque .....	44
13. Daily Inspection and Maintenance .....	45
14. Torque Indicator .....	47
15. Construction Drawings .....	48

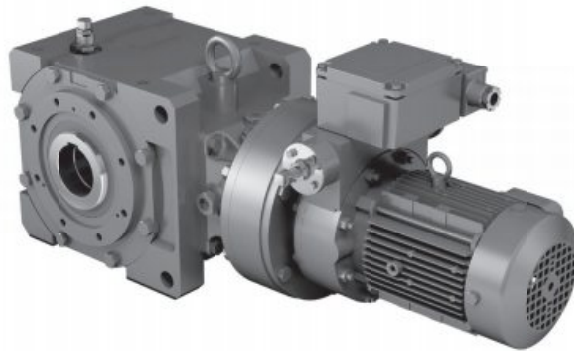

**⚠ DANGER**

- Do not handle the unit when cables are live. Be sure to turn off the power when performing operations on the unit; otherwise, electric shock may result.
- Connect a power cable to the unit in accordance with the maintenance manual; otherwise, electric shock or fire may result.
- Do not forcibly bend, pull, or clamp the power cable and lead wires; otherwise, electric shock or fire may result.

**⚠ CAUTION**

- When wiring, follow the facility's electrical codes and extension regulations to prevent burns, electric shocks, injuries, and fire.

**11-1 Wiring for a Spring-Loaded Limit Switch****(1) Limit Switch Type (1-Point Signal, 2-Point Signal, 3-Point Signal)**

- When the preset torque is reached, the dog activates the limit switch, which outputs a signal.
- Depending on manufacturing specifications 1 – 3 point signal output is available.  
(Types that have 1 – 3 limit switches.)

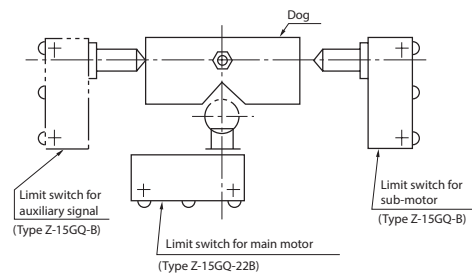

Fig. 36

**(2) Limit Switch Wiring**

- [1] Remove the terminal cover on the terminal box, feed the cable through the cable gland for marine use and connect it to the limit switch terminals.
- [2] Of the three lead wires, connect as follows:  
For contact point a, terminal symbols C (COMMON) and NO (NORMALLY OPEN)  
For contact point b, terminal symbols C (COMMON) and NC (NORMALLY CLOSED)
- [3] Make wiring within the terminal box. The construction of the terminal box makes wiring be possible.
- [4] The limit switch may activate at startup if startup torque exceeds preset torque (when shock occurs at startup, the motor is equipped with a brake, etc.). In this case, install a motor timer to disable the limit switch until the load torque becomes less than the preset torque.

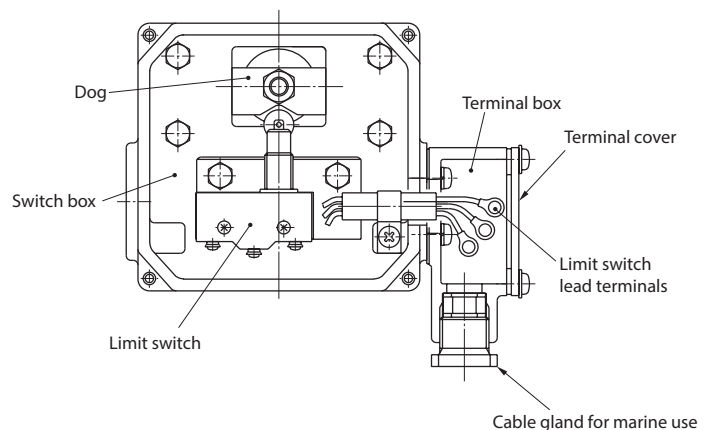

Fig. 37

- Note : 1. For 2-point signal systems, there are two terminal boxes; for 3-point signal systems, there are three terminal boxes.  
2. The cable gland for marine use conforms to JIS F 8801 (for boxes) and 15-b.

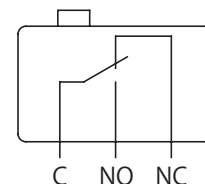

Fig. 38

- To prevent moisture from entering the cable port, seal openings with sealant (for example, putty).
- Do not move the position of the limit switch, or the torque limiter does not work properly because preset torque was changed.

### (3) Limit Switch Specifications

Table 28 Model

Products of OMRON Corporation.

Signal	Rotation Direction	Right or Left	Reversible Direction
Main motor OFF		Z-15GQ22-B (1 piece)	
Submotor or alarm ON		Z-15GQ-B (1 piece)	Z-15GQ-B (2 pieces)
Auxiliary signal		Z-15GQ-B (1 piece)	Please consult with us.

Table 29 Rating

Rated Voltage (V)	Noninductive Load (A)				Inductive Load (A)			
	Resistance Load		Lamp Load		Inductive Load		Motor Load	
	Normally Closed Circuit	Normally Open Circuit	Normally Closed Circuit	Normally Open Circuit	Normally Closed Circuit	Normally Open Circuit	Normally Closed Circuit	Normally Open Circuit
AC 125 250 500	15		3	1.5	15		5	2.5
	15		2.5	1.25	15		3	1.5
	10		1.5	0.75	6		1.5	0.75
DC 8 14 30 125 250	15		3	1.5	15		5	2.5
	15		3	1.5	10		5	2.5
	6		3	1.5	5		5	2.5
	0.5		0.5	0.5	0.05		0.05	0.05
	0.25		0.25	0.25	0.03		0.03	0.03

Table 30 Contact Point Specification

Inrush Current	Normally Closed Circuit	Normally Open Circuit
	Max. 30A	Max. 15A

Note : 1. Values shown in the table indicate steady-state current.

2. An inductive load is a power factor of 0.4 (AC) or more, or a time constant of 7 ms (DC) or less.
  3. A lamp load is a load with an inrush current 10 times as high.
  4. A motor load is a load with inrush current 6 times as high.
  5. Working ambient temperature: General type -25 to 80°C (no ice)
- Working ambient humidity: General type 35 to 85%RH (no condensation)

### (4) Example of How to Connect a Spring-Loaded Limit Switch (2-Point Signal, Dual Safety, Reversible Rotation)

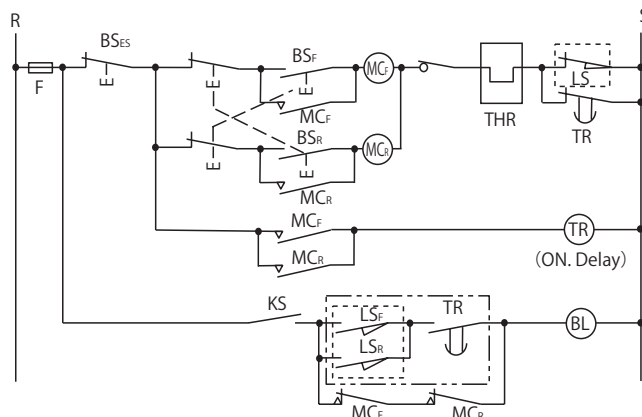
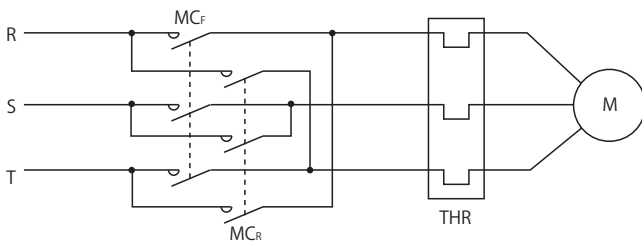

- M.....Motor
- MCF .....Electromagnetic switch for forward motor rotation
- MCR .....Electromagnetic switch for reverse motor rotation
- BSF .....Pushbutton switch for forward rotation
- BSR .....Pushbutton switch for reverse rotation
- BSES.....Pushbutton switch for stopping
- THR .....Thermal relay
- LS.....Limit switch (for forward, reverse and stop)
- LSF .....Limit switch (for forward alarm)
- LSR .....Limit switch (for reverse alarm)
- KS .....Knife switch
- TR .....Motor timer
- F .....Fuse
- BL.....Alarm

Note : 1. Limit switches LS, LSF and LSR surrounded by [ ] are built-in on BUDDYBOX with torque limiter other devices should be supplied by customer.

2. If there is an overload, LSF (LSR) and LS operate in order.
3. Devices within are [ ] not required for 1-point signals.

**⚠ CAUTION**

- Increasing the preset torque will cause the torque limiter to function at a torque value that exceeds the initial setpoint. Damage to the machine may occur.

### 12-1 Adjusting Preset Torque for the Spring-Loaded Limit Switch Model

- The preset torque is shown at the center of the adjusting scale plate [1] in the figure below. Torque values indicated by T1 and T2 are positioned at  $\pm 150^\circ$  from the center. Use T1 and T2 as points of reference when changing the preset torque.
- When it is necessary to increase or decrease the original preset torque, use the adjustment bolt [2]. Adjust torque within a range of  $\pm 25\%$  of the preset torque. Overscaling T1 and T2 is permitted within  $\pm 25\%$ . However, do not make adjustment in excess of the maximum preset torque. (See the selection table in the catalog.)
- An index [4] is stamped in the cut on the side of the threaded section of the adjustment bolt [2]. The index [4] is aligned with the end face of the case cover [3] when the mark [5] on the adjusting bolt [2] is located at the position of the preset torque on the adjusting scale plate [1]. Make fine adjustments using this alignment as a base. If the adjustment bolt is too tight or too loose, first reset the adjustment bolt to align the index [4] with the end face of the case cover [3]. Then make adjustments.

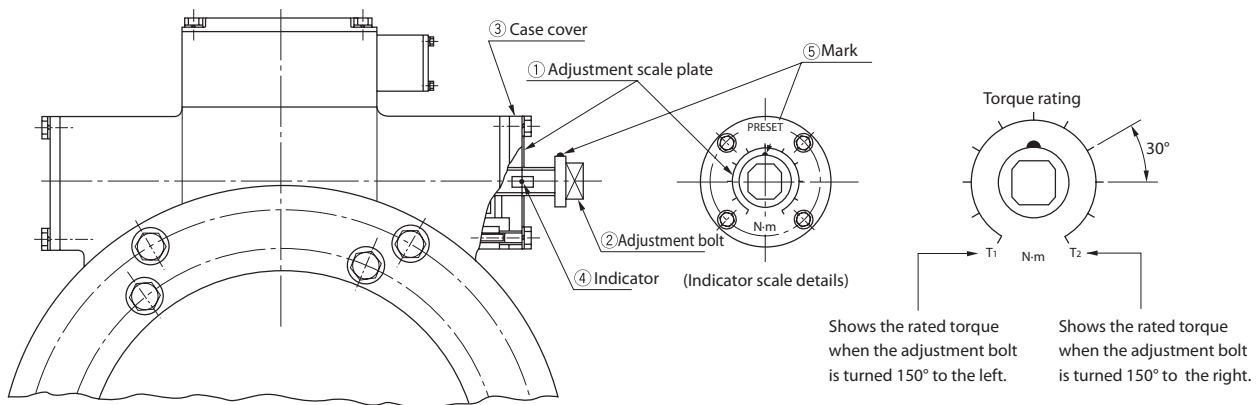

Fig. 39

- Note :
1. For the reversible rotation specification, an adjustment bolt and adjustment scale plate will be located on both sides.
  2. In the case of the B-type torque indicator (indicating a load factor of 0 – 100%), it is not possible to adjust the preset torque.

## 13-1 Torque Limiter, Daily Check

Open the switch box and check every time that oil is replenished or changed.

### (1) Limit Switch

- Use a tester to see if the limit switch activates normally.
- If it is possible to run the device, force the limit switch to activate while the machine is running to determine whether the torque limiter works properly.

### (2) Dog

- Check to determine whether the nut that secures the dog is loose.
- If it is possible to run the device, confirm that, on startup, the dog moves from its stopped condition.

### (3) Oil leakage

- Check to determine whether oil has leaked into the switch box.
- If oil leaks in, the limit switch may not activate, preventing the torque limiter from working.

- Do not move the position of the limit switch because moving it will change the preset torque value. This will prevent the torque limiter from working properly.
- A load test is performed and preset torque is adjusted when the device is shipped from the factory. If the customer disassembles and reassembles the device, the preset torque could change, causing the torque limiter to stop working properly. This is a source of damage to the device. Therefore, if disassembly or reassembly is required, contact the nearest accredited service station.

## 13-2 Lubrication method

Table 31, 32 provides approximate oil fill quantities.

- Helical BUDDYBOX with Torque Limiter requires the same amount supply of oil or grease as BUDDYBOX without Torque Limiter.
- Please refer to Page 22-34 for oil change interval, recommended lubricants, oil supply and discharges, timing of grease supply, recommended grease and procedure for supplying and draining of grease and more detail.
- Please contact us if there is no reference in the table.

Table 31 Bevel BUDDYBOX 5 Series with Torque Limiter

Approximate amount of oil Supply

Frame size	Mounting position					
	Y1, G1	Y3, G3	Y4, G4		Y5, G5	Y6, G6
			Output side	Input side		
5Z10DA	0.9	0.9	0.7	Long-life Grease	0.9	1.0
5Z12DA	0.9	0.9			1.1	1.1
5Z12DB	1.0	1.0			1.1	1.1
5A12DA	1.7	1.7	0.8		1.4	2.0
5A12DB	1.8	1.8			1.4	2.0
5B12DA	2.7	2.7			2.4	3.2
5B12DB	2.8	2.8	1.6	2.4	3.2	
5B14DA	2.9	2.9		2.6	3.4	
5B14DB	3.0	3.0		2.6	3.4	
5C14DA	5.5	5.5	3.5	Grease	5.1	5.7
5C14DB	5.5	5.5			5.2	5.7
5C14DC	5.5	5.5			5.2	5.8
5C16DA	6.1	6.1			5.9	6.5
5C16DB	6.2	6.2			6.0	6.5

Approximate amount of grease supply

Frame size	Mounting position
	Y4, G4
5Z10DA	Shaded
5Z12DA	
5Z12DB	
5A12DA	
5A12DB	
5B12DA	
5B12DB	8.5~12.5
5B14DA	20~30
5B14DB	20~30
5C14DA	8.5~12.5
5C14DB	20~30
5C14DC	40~60
5C16DA	20~30
5C16DB	40~60

Table 32 Bevel BUDDYBOX 4 Series with Torque Limiter

Approximate amount of oil Supply

Frame size	Mounting position								
	Y1, F1, G1 K1, V1	Y2, F2, G2, K2, V2, W2		Y3, F3, G3 K3, V3, W3	Y4, F4, G4, K4, W4		Y5, F5, G5 K5, V5	Y6, F6, G6 K6, V6	
		Output side	Input side		Output side	Input side			
4A10DA	1.7	1.0	Long-life Grease	1.7	1.1	Long-life Grease	1.4	1.9	
4A12DA	1.7			1.7			1.5	2.0	
4A12DB	1.8			1.8			1.5	2.0	
4B12DA	3.3	1.4		3.3	1.7		Long-life Grease	3.4	3.3
4B12DB	3.4			3.4				3.4	3.3
4B14DA	3.5			3.5				3.6	3.5
4B14DB	3.6	3.6	3.6	3.5					
4C14DA	5.6	3.5	Grease	5.6	2.7	Grease		5.3	5.9
4C14DB	5.6			5.6				5.4	5.9
4C14DC	5.6			5.6			5.4	6.0	
4C16DA	6.0			6.0			5.8	6.4	
4C16DB	6.1			6.1			5.9	6.4	
4C17DB	6.7			6.7			6.2	6.9	
4D16DA	10.1	5.0		10.1	4.6		Grease	9.8	10.5
4D16DB	10.1			10.1				9.8	10.5
4D17DA	10.2			10.2				9.8	10.6
4D17DB	10.5			10.5				10.2	10.9
4D17DC	10.7			10.7				10.3	11.0
4D18DA	10.8			10.8				10.5	11.2
4D18DB	11.7	11.7	11.4	12.1					
4E17DA	14.6	7.3	14.6	6.3	Grease	13.1		16.1	
4E17DB	14.7		14.7			13.2		16.2	
4E17DC	14.8		14.8			13.3		16.3	
4E18DA	14.8		14.8			13.3		16.3	
4E18DB	15.7		15.7			14.2		17.2	
4E19DA	17.5		17.5			16.0	19.0		
4E19DB	17.7	17.7	16.2	19.2					
4F18DA	20.1	11.3	20.1	7.3		Grease	18.6	21.5	
4F18DB	21.0		21.0				19.5	22.4	
4F19DA	22.6		22.6				21.1	24.0	
4F19DB	22.8		22.8				21.3	24.2	

Approximate amount of grease supply

Frame size	Mounting position
	Y2, F2, G2, K2, V2, W2 Y4, F4, G4, K4, W4
4A10DA	Shaded
4A12DA	
4A12DB	
4B12DA	
4B12DB	
4B14DA	
4B14DB	20~30
4C14DA	8.5~12.5
4C14DB	20~30
4C14DC	40~60
4C16DA	20~30
4C16DB	40~60
4C17DB	40~60
4D16DA	20~30
4D16DB	40~60
4D17DA	20~30
4D17DB	40~60
4D17DC	85~125
4D18DA	40~60
4D18DB	150~225
4E17DA	20~30
4E17DB	40~60
4E17DC	85~125
4E18DA	40~60
4E18DB	150~225
4E19DA	110~165
4E19DB	150~225
4F18DA	40~60
4F18DB	150~225
4F19DA	110~165
4F19DB	150~225

Note : 1.Output side: Bevel-gear, Input side: CYCLO Drive

2.Because shaded section indicates Long-life Grease models, they do not need to supply grease.

### 14-1 Torque Indicator

#### (1) Checking the Torque Indicator

- The torque indicator is zero adjusted, and the preset torque is adjusted before shipment.  
After the reducer has been connected to equipment, if zero is not indicated when the reducer is at rest, it is possible that a small load is already being applied to the output shaft. Do not readjust the zero point.
- The relationship between the direction of pointer deflection and slow speed shaft rotation (seen from the slow speed shaft side) is shown below.  
Single reduction type: pointer opposite direction of the slow speed shaft  
Double, triple reduction types: pointer in the same direction as the slow speed shaft
- The indicator scale displays the load factor, with 100% being the preset torque. Accuracy is within 10% of the overall load range.

#### (2) A-Type Torque Indicator

The A-type torque indicator displays load factors of 60 – 100% (depending on the combination of preset torque and reduction ratio 50 – 100%).

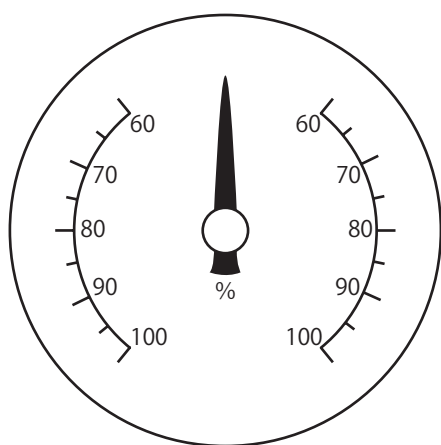

Fig.40 A-Type Torque Indicator (60 – 100% load factor display)

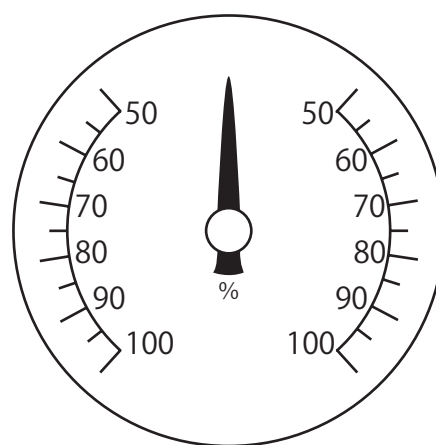

Fig.41 A-Type Torque Indicator (50 – 100% load factor display)

- The pointer may deflect slightly when stopped or under no load. This is not a problem.
- For the reversible rotation specification, when left and right preset torques differ, the pointer position will be slightly offset.

#### (3) B-Type Torque Indicator

The B-type torque indicator displays load factors of 0 – 100%.

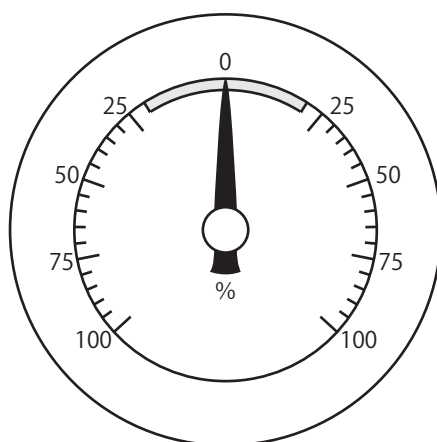



Fig.42 B-Type Torque Indicator (0 – 100% load factor display)

- In the case of a B-type torque indicator, the pointer will stop in the range of  when load is removed.
- Preset torque cannot be changed. Do not turn the adjustment bolt.

## 15-1 Construction Drawings

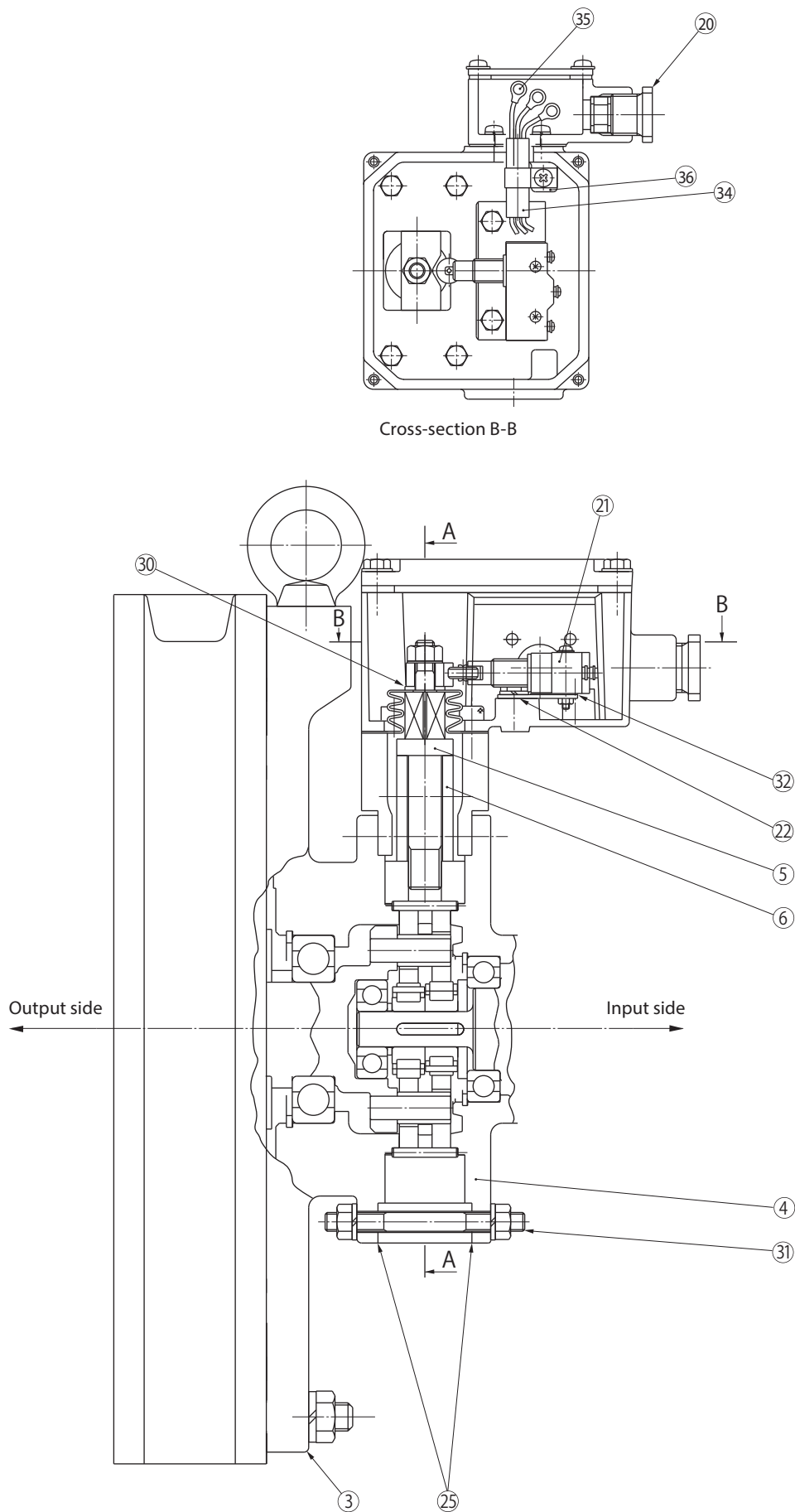
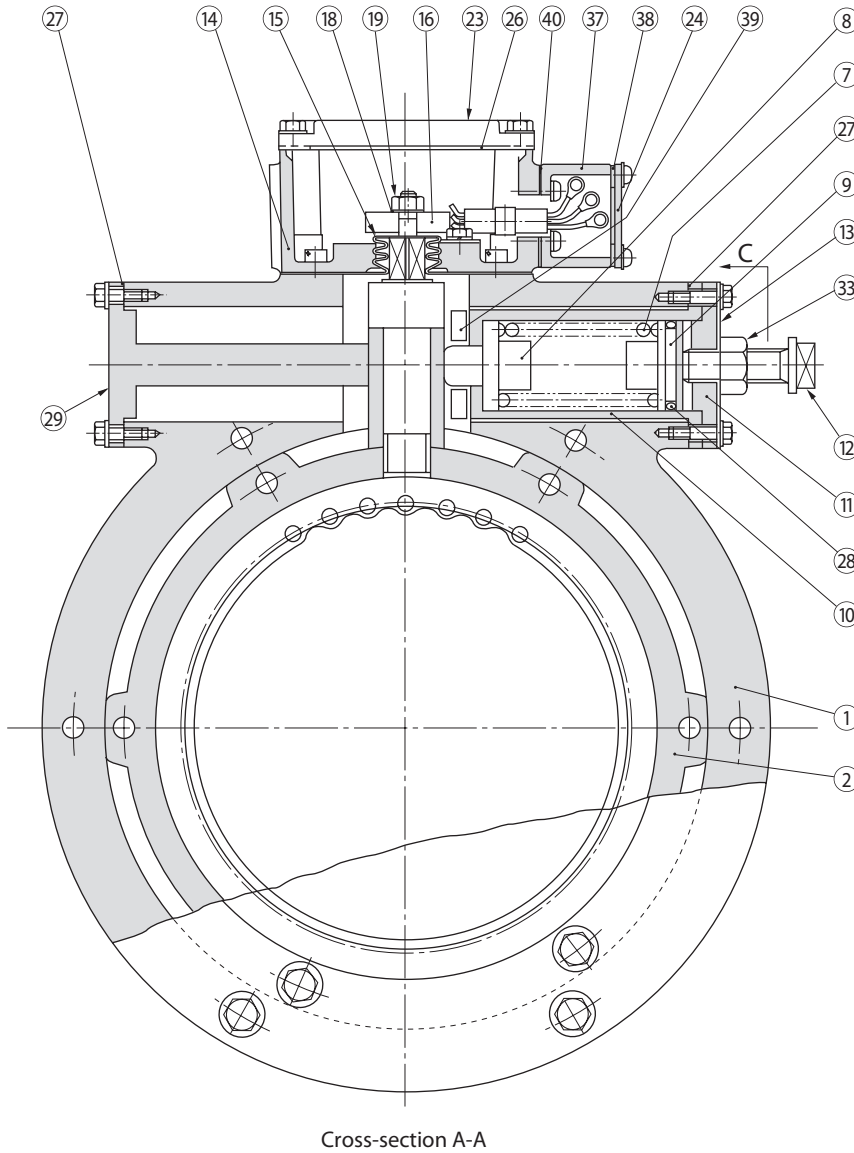
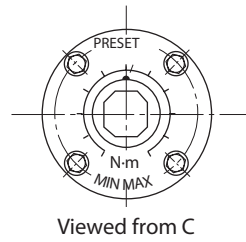

Fig.43 Single stage type bevel-gear or helical-gear + Double stage type CYCLO Drive





Cross-section A-A

Fig.44 Single stage type bevel-gear or helical-gear + Double stage type CYCLO Drive

Table 33 Torque Limiter Principal Parts

No.	Part Name
1	Fixed ring gear housing
2	Ring gear housing
3	Intermediate cover
4	Intermediate cover (Internal cover Motor flange bracket)
5	Dog bar
6	Bushing
7	Spring
8	Spring holder plate A
9	Spring holder plate B
10	Spring case
11	Case cover
12	Adjustment bolt
13	Adjustment scale plate
14	Switch box
15	Bellows
16	Dog
18	Toothed washer
19	Dog clamping nut
20	Cable gland for marine use
21	Limit switch
22	Switch mounting bracket
23	Switch box cover
24	Terminal cover
25	Gasket
26	Gasket
27	Gasket
28	O-ring
29	Stopper
30	Flat washer
31	Bolts for fixed ring gear housing
32	Insulation board
33	Stopping nut
34	Cabtyre cable
35	Limit switch lead terminal
36	Terminal plate (with clamp)
37	Terminal box
38	Gasket
39	Spacer
40	Gasket

## 15-2 Torque Indicator Construction Drawings

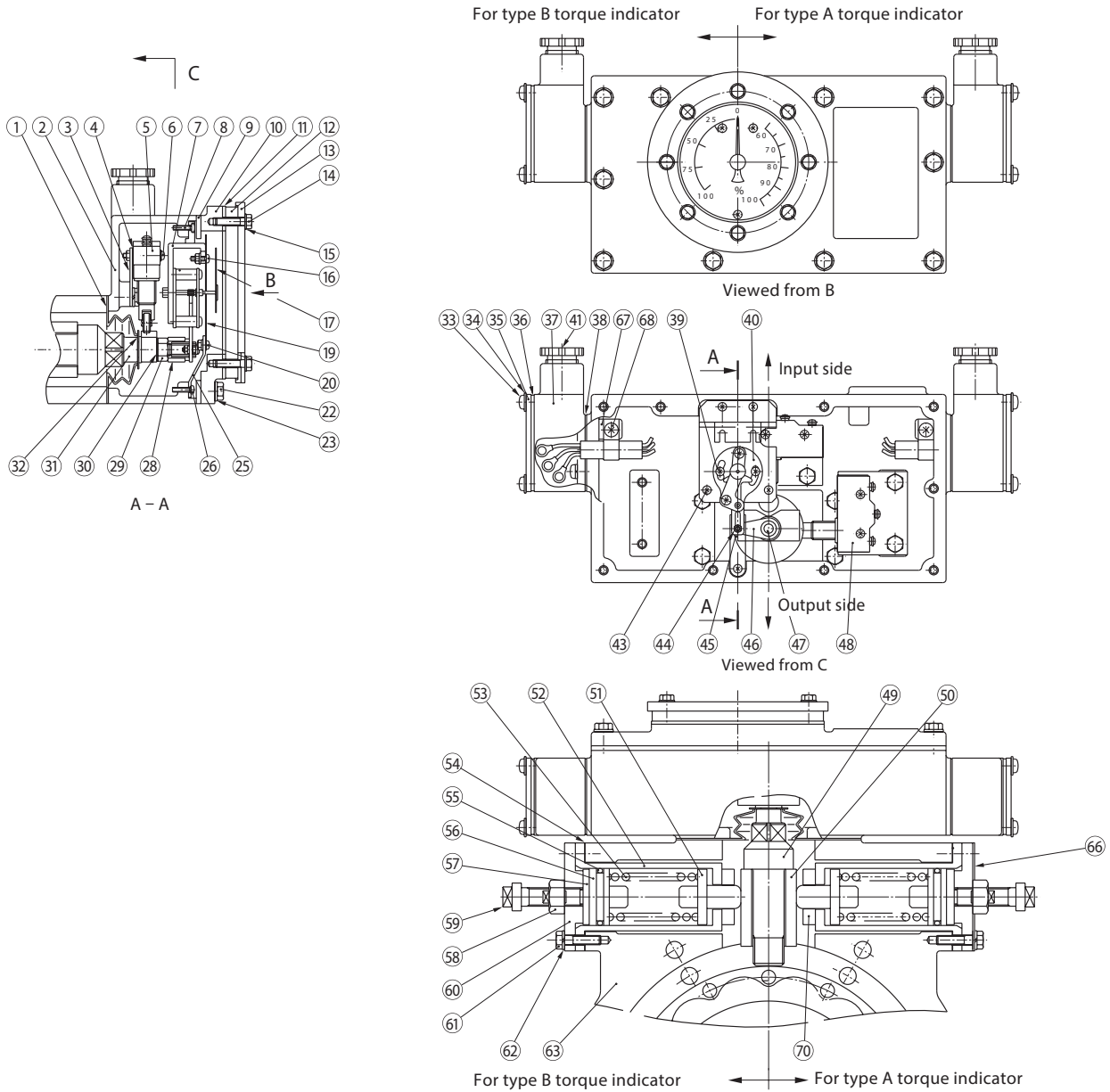

Fig.45 Torque Indicator

Table 34 Torque Indicator Principal Parts

No.	Part Name
1	Bellows
2	Switch box
3	Switch mounting bracket
4	Insulation board
5	Microswitch (for stopping motor)
6	Philips pan head machine screw
7	Motor assembly mounting base
8	Philips pan head machine screw
9	Gasket
10	Switch cover
11	Gasket
12	Transparent cover
13	Holding plate for transparent cover
14	Upper bolt
15	Washer with rubber
16	Philips pan head machine screw
17	Pointer
19	Scale plate
20	Philips pan head machine screw
22	Upper bolt
23	Washer with rubber

No.	Part Name
25	Scale plate mounting base
26	Philips pan head machine screw
28	Spacer for rod
29	Upper nut
30	Toothed washer
31	Dog
32	Flat washer
33	Upper bolt
34	Washer with rubber
35	Terminal cover
36	Gasket
37	Terminal box
38	Gasket
39	Philips pan head machine screw
40	Internal machine
41	Cable gland for marine use
43	Philips pan head machine screw
44	Sector
45	Nut
46	Rod
47	Bushing for rod

No.	Part Name
48	Microswitch (for alarm)
49	Dog bar
50	Bushing
51	Spring holder plate A
52	Spring case
53	Spring
54	Gasket
55	O-ring
56	Spring holder plate B
57	Preload plate
58	Lock nut
59	Adjustment bolt
60	Case cover
61	Upper bolt
62	Washer with rubber
63	Fixed ring gear housing
66	Adjustment scale plate
67	Terminal plate
68	Upper bolt
70	Spacer

The scope of our product warranty is limited to our manufacturing range.

Warranty (period and contents)

<b>Warranty Period</b>	The product warranty period is 18 months after delivery, 18 months after shipment of the product from the seller, or 12 months from product commissioning, whichever is first.
<b>Warranty Conditions</b>	<p>In the event that any problem or damage to the product arises during the “Warranty Period” from defects in the product whenever the product is properly installed and combined with the buyer’s equipment or machines, maintained as specified in the maintenance manual, and properly operated under the conditions described in the catalog or as otherwise agree on in writing between the seller and the buyer or its customers, the seller will provide, at its sole discretion, appropriate repair or replacement of the product, without charge, at a designated facility, except as stipulated in the “Warranty Exclusions” described below.</p> <p>However, if the product is installed or integrated into the Buyer’s equipment or machines, the seller does not reimburse the following costs: removal or reinstallation of the product or other incidental costs related thereto, any lost opportunity, any profit loss or other incidental or consequential losses or damage incurred by the buyer or its customers.</p>
<b>Warranty Exclusions</b>	<p>Notwithstanding the above warranty, the warranty as set forth herein does not apply to any problem or damage to the product caused by:</p> <ol style="list-style-type: none"> <li>1. Installation, connection, combination or integration of the product with or into the other equipment or machine that is rendered by any person or entity other than the seller;</li> <li>2. Insufficient maintenance or improper operation by the buyer or its customers, such that the product is not maintained in accordance with the maintenance manual provided or designated by the seller;</li> <li>3. Improper use or operation of the product by the buyer or its customers without informing the Seller, including, without limitation, the buyer’s or its customers’ operation of the product not in conformity with the specifications and use of lubricating oil that is not recommended by the seller;</li> <li>4. Any problem or damage to any equipment or machine into or with which the Product is installed, connected or combined, or on any specifications particular to the buyer or its customers;</li> <li>5. Any changes, modifications, improvements or alterations to the product or those functions that are rendered on the product by any person or entity other than the seller;</li> <li>6. Any parts in the product that are supplied or designated by the buyer or its customers;</li> <li>7. Earthquake, fire, flood, sea breeze, gas, thunder, acts of God or any other reasons beyond the control of the seller;</li> <li>8. Normal wear and tear or deterioration of the product’s parts, such as bearings and oil seals; and</li> <li>9. Any other problems with or damage to the product that are not attributable to the seller.</li> </ol>

# Worldwide Locations

## **U.S.A**

**Sumitomo Machinery Corporation of America (SMA)**  
4200 Holland Blvd. Chesapeake, VA 23323, U.S.A.  
TEL (1)757-485-3355 FAX (1)757-485-7490

## **Canada**

**SM Cyclo of Canada, Ltd. (SMC)**  
1453 Cornwall Road, Oakville, Canada ON L6J 7T5  
TEL (1)905-469-1050 FAX (1)905-469-1055

## **Mexico**

**SM Cyclo de Mexico, S.A. de C.V. (SMME)**  
Av. Desarrollo 541, Col. Finsa, Guadalupe,  
Nuevo León, México, CP67132  
TEL (52)81-8144-5130 FAX (52)81-8144-5130

## **Brazil**

**Sumitomo Industrias Pesadas do Brasil Ltda. (SHIB)**  
Rodovia do Acucar (SP-075) Km 26  
Itu, Sao Paulo, Brasil  
TEL (55)11-4886-1000 FAX (55)11-4886-1000

## **Chile**

**SM-Cyclo de Chile Ltda. (SMCH)**  
Camino Lo Echevers 550, Bodegas 5 y 6,  
Quilicura, Región Metropolitana, Chile  
TEL (56)2-892-7000 FAX (56)2-892-7001

## **Argentina**

**SM-Cyclo de Argentina S.A. (SMAR)**  
Ing Delpini 2230, B1615KGB Grand Bourg,  
Malvinas Argentinas, Buenos Aires, Argentina  
TEL (54)3327-45-4095 FAX (54)3327-45-4099

## **Guatemala**

**SM Cyclo de Guatemala Ensambladora, Ltda. (SMGT)**  
Parque Industrial Unisur, 0 Calle B 19-50 Zona 3,  
Bodega D-1 Delta Bárcenas en Villa Nueva, Guatemala  
TEL (502)6648-0500 FAX (502)6631-9171

## **Colombia**

**SM Cyclo Colombia, S.A.S. (SMCO)**  
Parque Industrial Celta, Km 7.0 Autopista Medellín,  
Costado Occidental, Funza, Cundinamarca, Colombia  
TEL (57)1-826-9766

## **Peru**

**SM Cyclo de Perú, S.A.C (SMPE)**  
Jr. Monte Rosa 255, Oficina 702, Lima,  
Santiago de Surco, Perú  
TEL (51)1-713-0342 FAX (51)1-715-0223

## **Germany**

**Sumitomo (SHI) Cyclo Drive Germany GmbH (SCG)**  
Cyclostraße 92, 85229 Markt Indersdorf, Germany  
TEL (49)8136-66-0 FAX (49)8136-5771

## **Austria**

**Sumitomo (SHI) Cyclo Drive Germany GmbH (SCG)**  
**SCG Branch Austria Office**  
Gruentalerstraße 30A, 4020 Linz, Austria  
TEL (43)732-330958 FAX (43)732-331978

## **Belgium**

**Hansen Industrial Transmissions NV (HIT)**  
Leonardo da Vincilaan 1, Edegem, Belgium  
TEL (32)34-50-12-11 FAX (32)34-50-12-20

## **France**

**SM-Cyclo France SAS (SMFR)**  
8 Avenue Christian Doppler, 77700 Serris, France  
TEL (33)164171717 FAX (33)164171718

## **Italy**

**SM-Cyclo Italy Srl (SMIT)**  
Via dell' Artigianato 23, 20010 Cornaredo (MI), Italy  
TEL (39)293-481101 FAX (39)293-481103

## **Spain**

**SM-Cyclo Iberia, S.L.U. (SMIB)**  
C/Gran Vía Nº 63 Bis, Planta 1, Departamento 1B  
48011 Bilbao-Vizcaya, Spain  
TEL (34)9448-05389 FAX (34)9448-01550

## **United Kingdom**

**SM-Cyclo UK Ltd. (SMUK)**  
Unit 29, Bergen Way, Sutton Fields Industrial Estate,  
Kingston upon Hull, HU7 0YQ, East Yorkshire,  
United Kingdom  
TEL (44)1482-790340 FAX (44)1482-790321

## **Turkey**

**SM Cyclo Turkey Güç Aktarım Sis. Tic. Ltd. Sti. (SMTR)**  
Barbaros Mh. Çiğdem Sk. Ağaoğlu, Office Mrk. No:1 Kat:4 D.18  
Ataşehir, İstanbul, Turkey  
TEL (90)216-250-6069 FAX (90)216-250-5556

## **India**

**Sumi-Cyclo Drive India Private Limited (SDI)**  
Gat No. 186, Rasoni Industrial Park, Alandi Markal Road,  
Fulgaon-Pune, Maharashtra, India  
TEL (91)96-0774-5353

## **China**

**Sumitomo (SHI) Cyclo Drive Shanghai, Ltd. (SCS)**  
11F, SMEG Plaza, No. 1386 Hongqiao Road,  
Changning District, Shanghai, China 200336  
TEL (86)21-3462-7877 FAX (86)21-3462-7922

## **Hong Kong**

**SM-Cyclo of Hong Kong Co., Ltd. (SMHK)**  
Room 19, 28th Floor, Metropole Square, No.2 On  
Yiu Street, Shatin, New Territories, Hong Kong  
TEL (852)2460-1881 FAX (852)2460-1882

## **Korea**

**Sumitomo (SHI) Cyclo Drive Korea, Ltd. (SCK)**  
Royal Bldg. 19 Rm. 913, 5 Saemunan-ro 5-Gil Jongro-Gu  
Seoul, Korea 03173  
TEL (82)2-730-0151 FAX (82)2-730-0156

## **Taiwan**

**Tatung SM-Cyclo Co., Ltd. (TSC)**  
22 Chungshan N. Road 3rd., Sec. Taipei, Taiwan 104,  
R.O.C.  
TEL (886)2-2595-7275 FAX (886)2-2595-5594

## **Singapore**

**Sumitomo (SHI) Cyclo Drive Asia Pacific Pte. Ltd. (SCA)**  
15 Kwong Min Road, Singapore 628718  
TEL (65)6591-7800 FAX (65)6863-4238

## **Philippines**

**Sumitomo (SHI) Cyclo Drive Asia Pacific Pte. Ltd. Philippines Branch Office (SMPH)**  
C4 & C5 Buildings Granville Industrial Complex, Carmona,  
Cavite 4116, Philippines  
TEL (63)2-584-4921 FAX (63)2-584-4922

## **Vietnam**

**SM-Cyclo (Vietnam) Co., Ltd. (SMVN)**  
Factory 2B, Lot K1-2-5, Road No. 2-3-5A,  
Le Minh Xuan Industrial Park, Binh Chanh Dist.,  
HCMC, Vietnam  
TEL (84)8-3766-3709 FAX (84)8-3766-3710

## **Malaysia**

**SM-Cyclo (Malaysia) Sdn. Bhd. (SMMA)**  
No.7C, Jalan Anggerik Mokara 31/56, Kota Kemuning,  
Seksyen 31, 40460 Shah Alam, Selangor Darul Ehsan,  
Malaysia  
TEL (60)3-5121-0455 FAX (60)3-5121-0578

## **Indonesia**

**PT. SM-Cyclo Indonesia (SMID)**  
Jalan Sungkai Blok F 25 No. 09 K, Delta Silicon III,  
Lippo Cikarang, Bekasi 17530, Indonesia  
TEL (62)21-2961-2100 FAX (62)21-2961-2211

## **Thailand**

**SM-Cyclo (Thailand) Co., Ltd. (SMTH)**  
195 Empire Tower, Unit 2103-4, 21st Floor, South  
Sathorn Road, Yannawa, Sathorn, Bangkok 10120,  
Thailand  
TEL (66)2670-0998 FAX (66)2670-0999

## **Australia**

**Sumitomo (SHI) Hansen Australia Pty. Ltd. (SHAU)**  
181 Power St, Glendenning, NSW 2761, Australia  
TEL (61)2-9208-3000 FAX (61)2-9208-3050

## **Japan**

**Sumitomo Heavy Industries, Ltd. (SHI)**  
ThinkPark Tower, 1-1 Osaki 2-chome, Shinagawa-ku,  
Tokyo 141-6025, Japan  
TEL (81)3-6737-2511 FAX (81)3-6866-5160

Specifications, dimensions, and other items are subject to change without prior notice.

 **Sumitomo Heavy Industries, Ltd.**

**Power Transmission & Controls Group**

Headquarter ThinkPark Tower, 1-1 Osaki 2-chome, Shinagawa-ku, Tokyo 141-6025, Japan

**No.CM2020E-3.0**

EA11 Printed 2020.04